

HARD CHROME COATED INSERTS

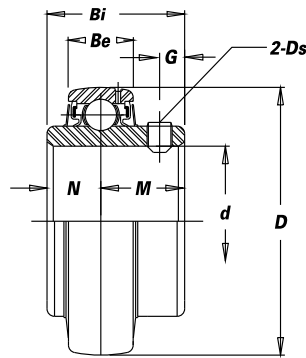

Seal Options



CUC

CUC Set screw lock.

| | |
|----------------------|-----------------------|
| Rings | Hard Chrome Coated |
| Balls | 440 Stainless Steel |
| Seal | Silicone Rubber |
| Slinger & Seal Frame | 302 Stainless Steel |
| Retainer | 302 Stainless Steel* |
| Set Screws | 410 Stainless Steel |
| Lubrication | H-1 Food Grade Grease |

* Chrome coated for sizes 213-215

| Bearing No. | Bore Dia. of Bearing | | Dimensions (in.) (mm) | | | | | | | Basic Load Rating (lbs.) | Basic Static Load Rating (lbs.) | Weight (lbs.) |
|---------------------------------------|---------------------------|----------|-----------------------|----------------|----------------|----------------|----------------|----------------|-----------------|--------------------------|---------------------------------|------------------------------|
| | <i>d</i> | <i>d</i> | <i>D</i> | <i>Bi</i> | <i>Be</i> | <i>N</i> | <i>M</i> | <i>G</i> | <i>Ds</i> (in.) | | | |
| CUC 204-12 204 | 3/4 | 20 | 1.8504 47.0 | 1.2205 31.0 | 0.6299 16.0 | 0.5000 12.7 | 0.7205 18.3 | 0.1969 5.0 | 1/4-28UNF | 2,740 | 1,600 | 0.35 0.35 |
| CUC 205-14 205 205-16 | 7/8 1 | 25 | 2.0472 52.0 | 1.3386 34.0 | 0.6693 17.0 | 0.5630 14.3 | 0.7756 19.7 | 0.2165 5.5 | 1/4-28UNF | 3,010 | 1,750 | 0.51 0.44 0.44 |
| CUC 206-18 206 206-19 206-20 | 1 1/8 1 3/16 1 1/4S | 30 | 2.4409 62.0 | 1.5000 38.1 | 0.7480 19.0 | 0.6260 15.9 | 0.8740 22.2 | 0.2362 6.0 | 1/4-28UNF | 4,200 | 2,430 | 0.75 0.71 0.71 0.71 |
| CUC 207-20 207-22 207 207-23 | 1 1/4 1 3/8 1 7/16 | 35 | 2.8346 72.0 | 1.6890 42.9 | 0.7874 20.0 | 0.6890 17.5 | 1.0000 25.4 | 0.2559 6.5 | 5/16-24UNF | 5,535 | 3,340 | 1.19 1.06 1.06 0.99 |
| CUC 208-24 208 | 1 1/2 | 40 | 3.1496 80.0 | 1.9370 49.2 | 0.8268 21.0 | 0.7480 19.0 | 1.1890 30.2 | 0.3150 8.0 | 5/16-24UNF | 6,375 | 3,960 | 1.50 1.41 |
| CUC 209-27 209-28 209 | 1 11/16 1 3/4 | 45 | 3.3465 85.0 | 1.9370 49.2 | 0.8661 22.0 | 0.7480 19.0 | 1.1890 30.2 | 0.3150 8.0 | 5/16-24UNF | 7,110 | 4,460 | 1.63 1.54 1.50 |
| CUC 210-31 210 210-32 | 1 15/16 2S | 50 | 3.5433 90.0 | 2.0315 51.6 | 0.9449 24.0 | 0.7480 19.0 | 1.2835 32.6 | 0.3543 9.0 | 3/8-24UNF | 7,400 | 4,910 | 1.81 1.76 1.66 |
| CUC 211-32 211-35 | 2 2 3/16 | | 3.9370 100.0 | 2.1890 55.6 | 0.9843 25.0 | 0.8740 22.2 | 1.3150 33.4 | 0.3543 9.0 | 3/8-24UNF | 9,490 | 6,440 | 2.78 2.40 |
| CUC 212-36 212-39 | 2 1/4 2 7/16 | | 4.3307 110.0 | 2.5630 65.1 | 1.0630 27.0 | 1.0000 25.4 | 1.5630 39.7 | 0.4134 10.5 | 3/8-24UNF | 11,500 | 7,940 | 3.68 3.20 |
| CUC 213-40 | 2 1/2 | | 4.7244 120.0 | 2.5630 65.1 | 1.1024 28.0 | 1.0000 25.4 | 1.5630 39.7 | 0.4724 12.0 | 1/2-20UNF | 12,400 | 8,760 | 4.28 |
| CUC 215-47 215-48 | 2 15/16 3 | | 5.1181 130.0 | 3.0630 77.8 | 1.2598 32.0 | 1.3110 33.3 | 1.7520 44.5 | 0.4724 12.0 | 1/2-20UNF | 14,620 | 10,540 | 5.02 4.67 |