

9 8 7 6 5 4 3 2 1

G  
F  
E  
D  
C  
B  
A

G  
F  
E  
D  
C  
B  
A

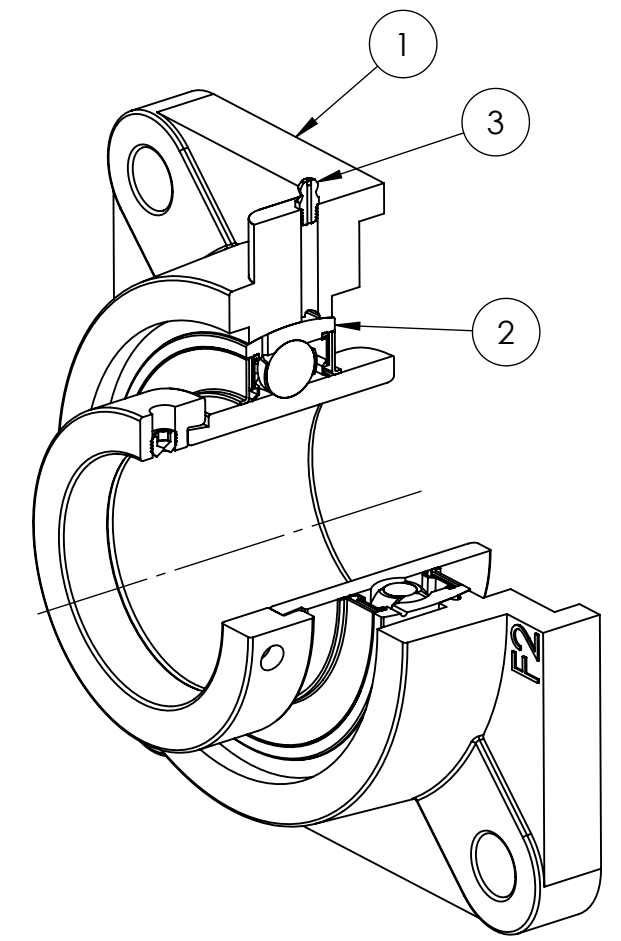
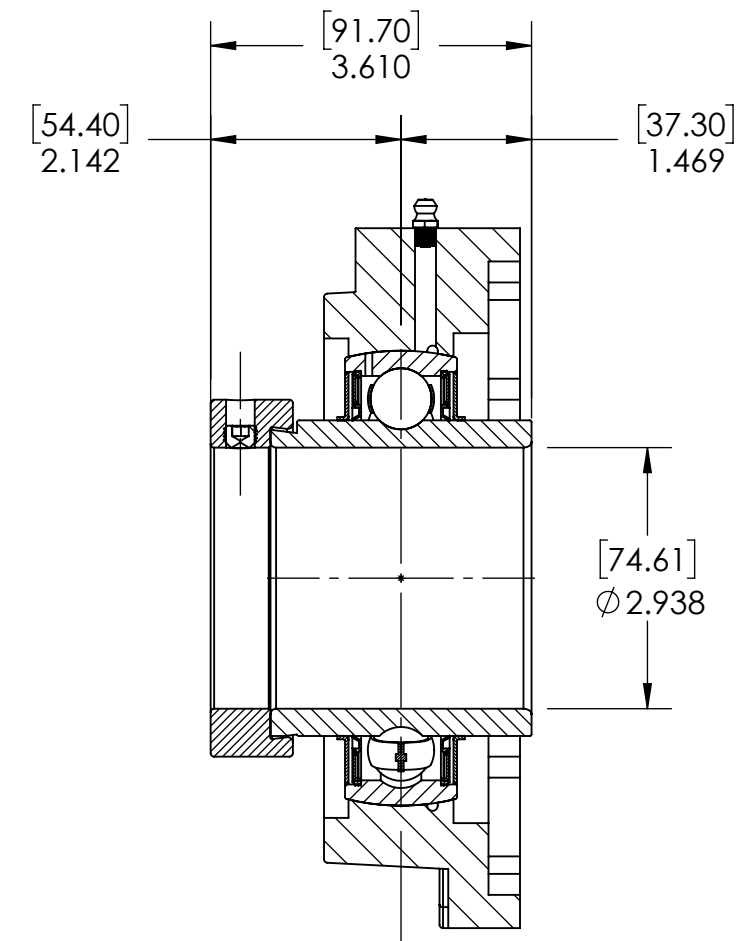
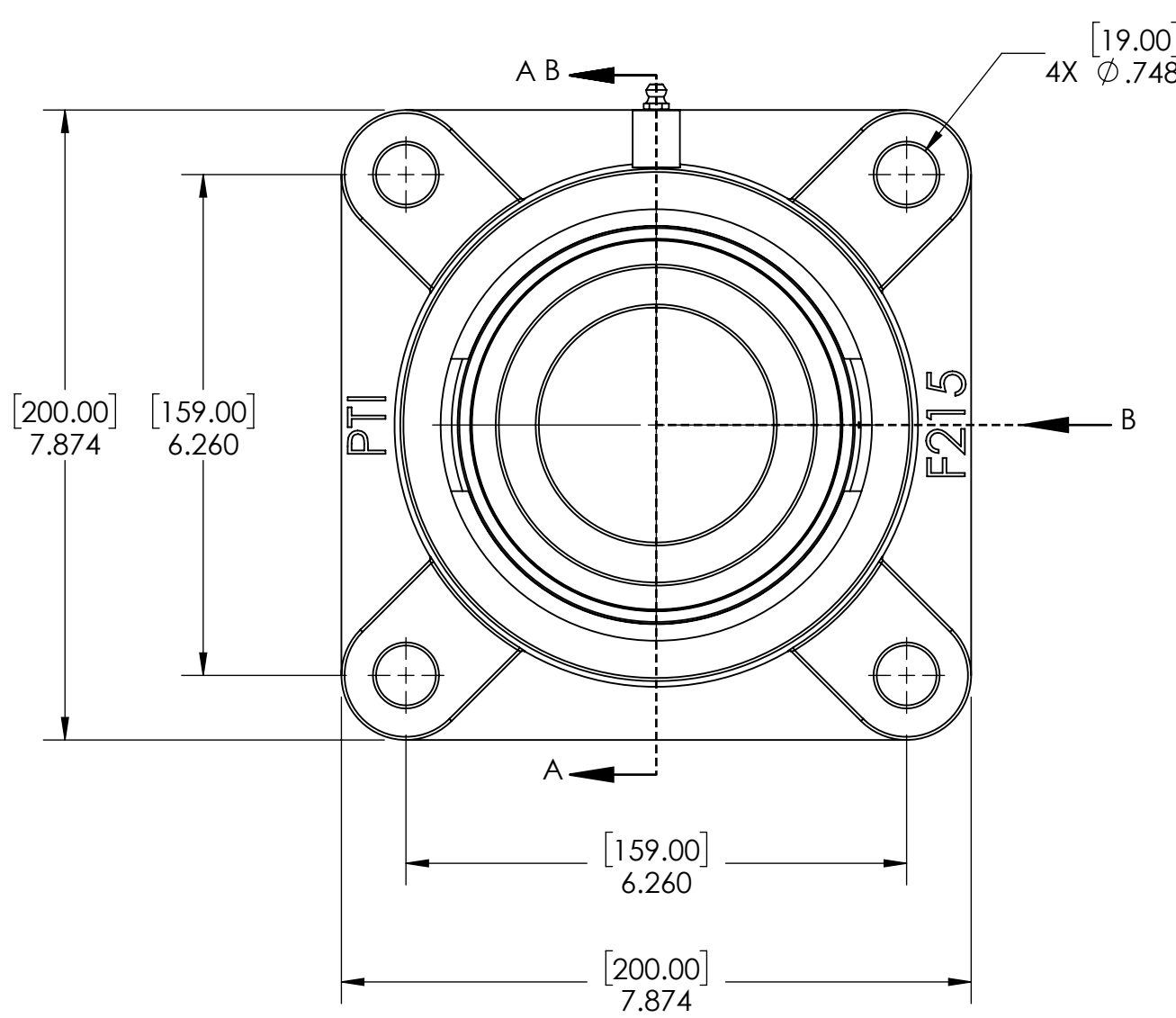
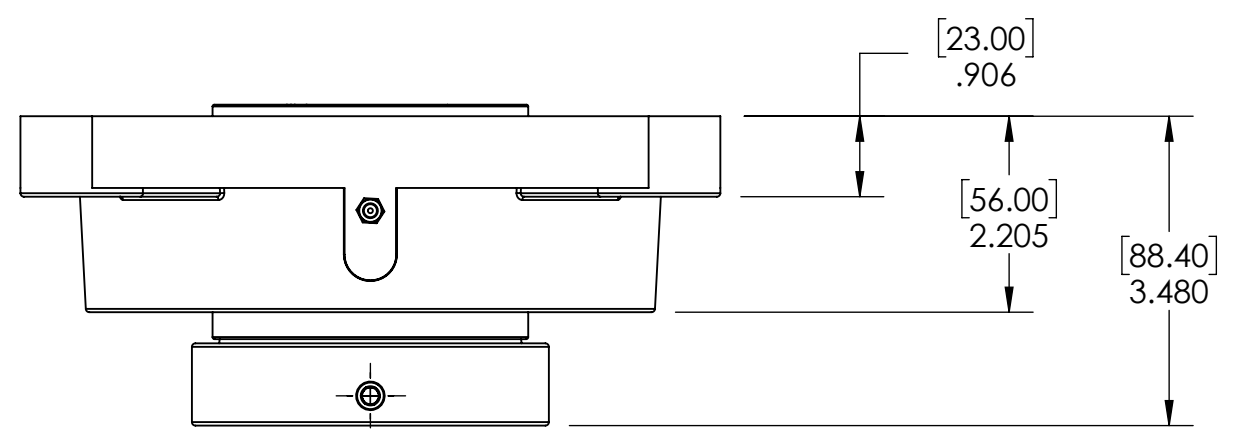

SECTION VIEW A-A

SPECIFICATIONS	
UNITS:	IN (mm)
LOAD RATINGS	C: 14,000 LBS Co: 10,050 LBS
SPEED RATING	2300 RPM
GREASE TYPE	NLGI #2
GREASE FILL	40%
OPERATING TEMP	10°F - 200°F
SEAL TYPE	B-TYPE
INTERNAL CLEARANCE	C3
TORQUE SETTING ON SET SCREWS	

**SOLVE** INDUSTRIAL MOTION GROUP  
**PTI**  
 DWG. NO.

WEIGHT	16.10 LBS
MATERIAL	SEE BOM
COATING	SEE BOM
DRAWN	SEC 01/10/2025
CHECKED	SEC 01/10/2025
APPROVED	
THIRD ANGLE PROJECTION	
<small>PROPRIETARY AND CONFIDENTIAL          THE INFORMATION CONTAINED IN THIS DRAWING IS THE SOLE PROPERTY OF SOLVE IMG. ANY REPRODUCTION IN PART OR AS A WHOLE WITHOUT THE WRITTEN PERMISSION OF SOLVE IMG IS PROHIBITED.</small>	

ITEM NO.	PART NUMBER	MATERIAL	COATING	QTY.
3	M6 ZERK	STEEL	ZINC PLATED	1
2	HC215-47	BEARING STEEL	N/A	1
1	F215	CAST IRON	POWDER COAT	1

DATE	BY	REVISION DESCRIPTION	REV
ITEM DESCRIPTION:			SCALE
HCF215-47			1:6
			REV
			-

9 8 7 6 5 4 3 2 1