

9 8 7 6 5 4 3 2 1

G F E D C B A

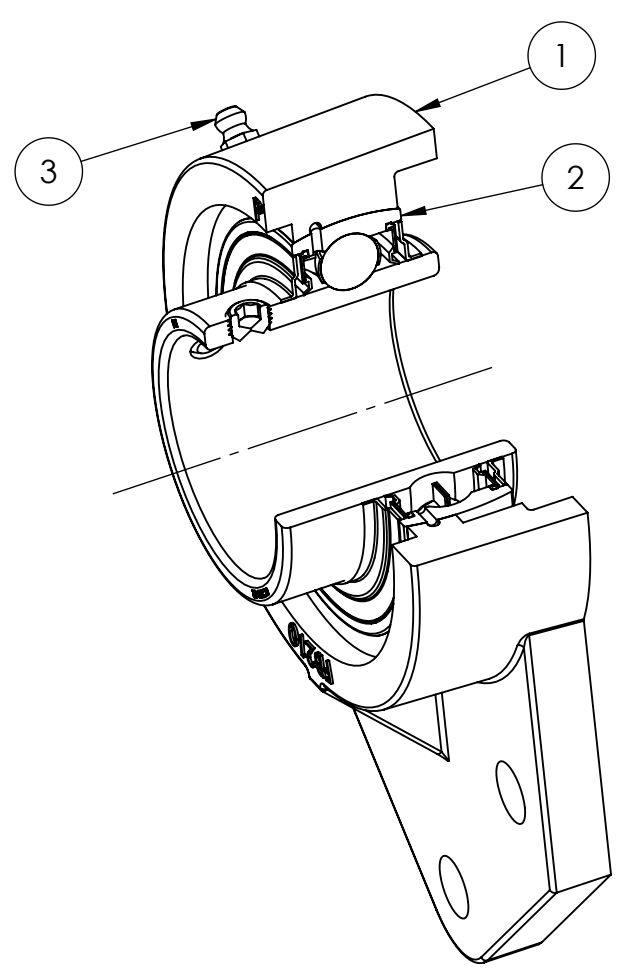
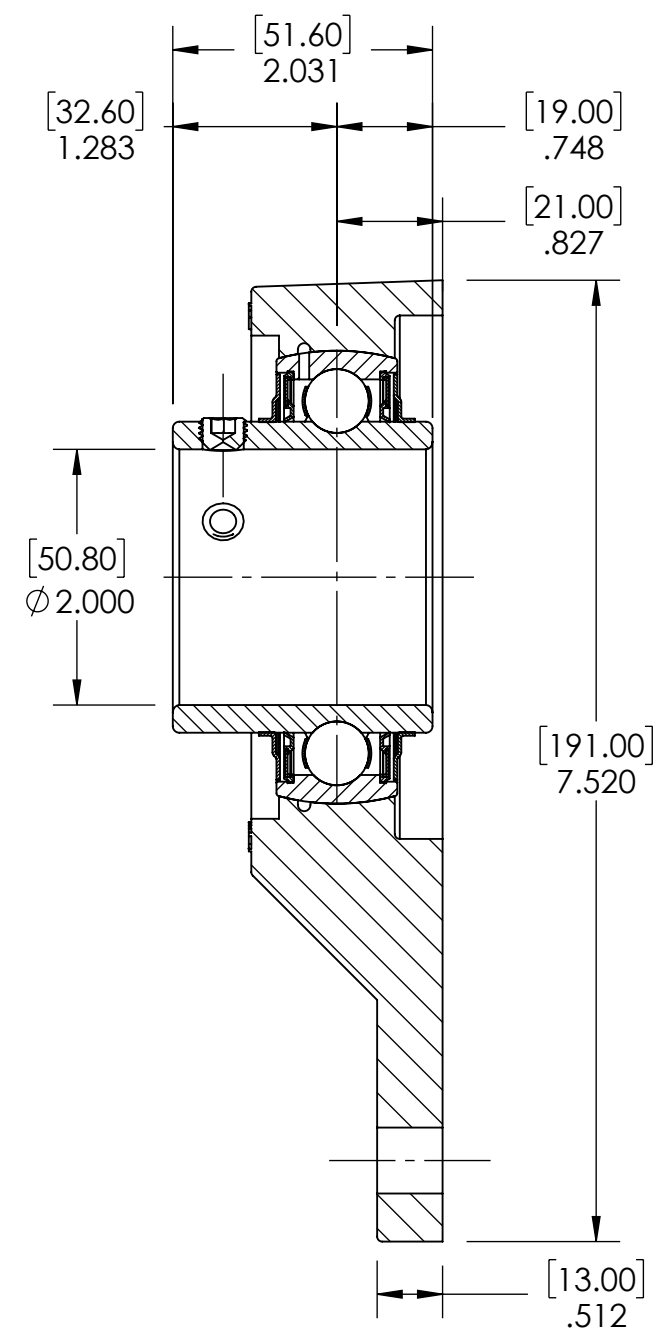
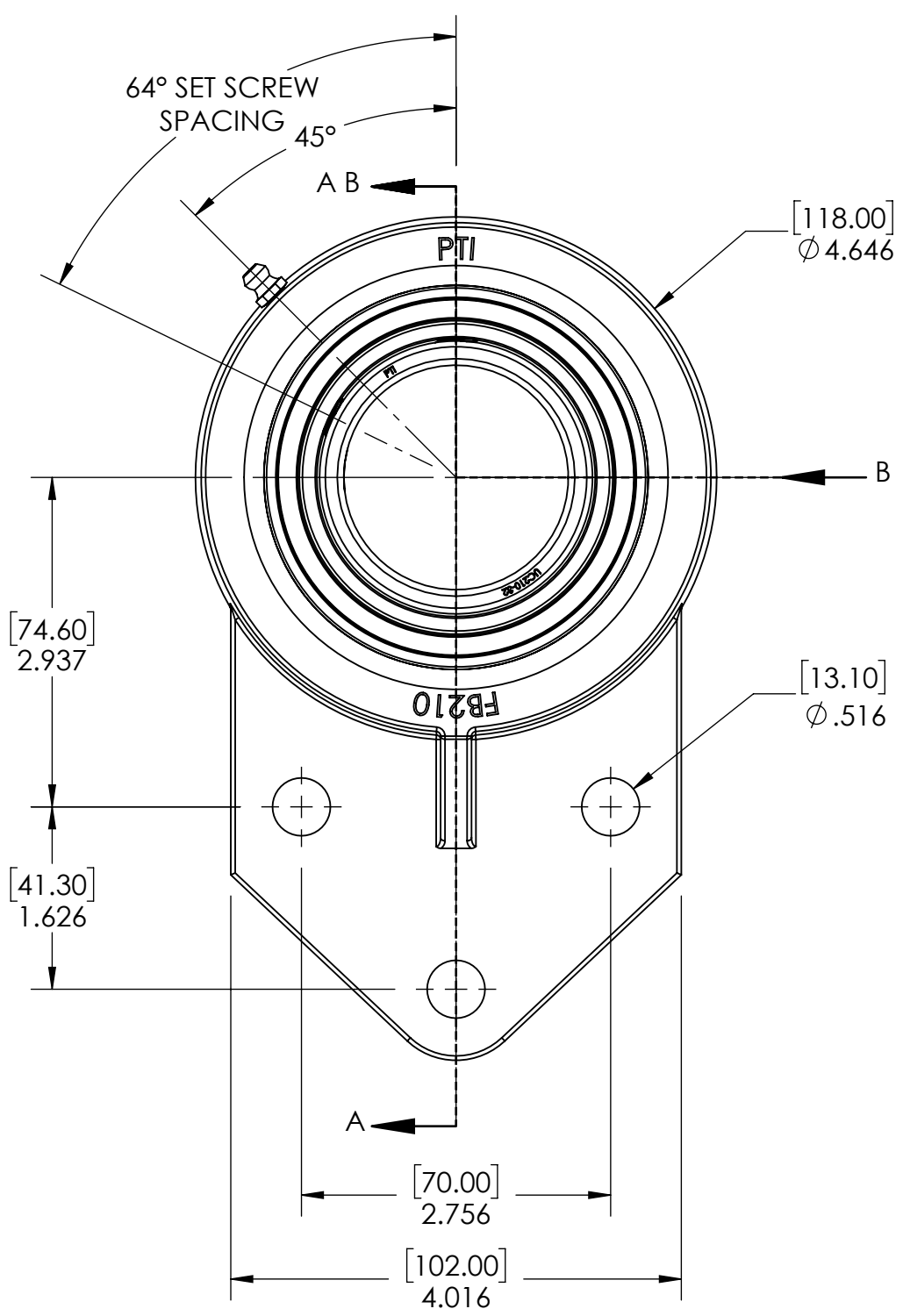
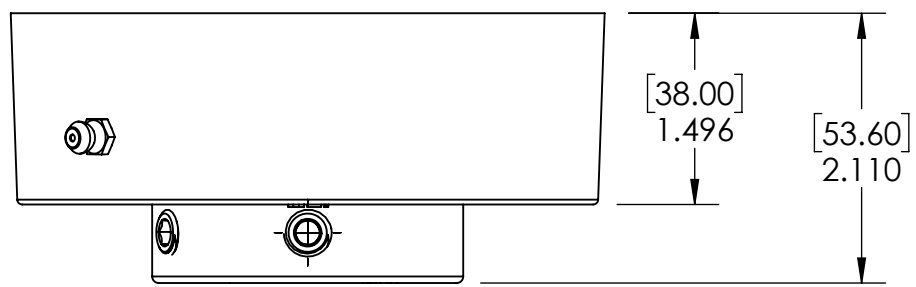

SECTION VIEW A-A

SPECIFICATIONS	
UNITS:	IN (mm)
LOAD RATINGS	C: 7,900 LBS Co: 5,190 LBS
SPEED RATING	3400 RPM
GREASE TYPE	NLGI #2
GREASE FILL	40%
OPERATING TEMP	10°F - 200°F
SEAL TYPE	B-TYPE
INTERNAL CLEARANCE	C3
TORQUE SETTING ON SET SCREWS	

SOLVE
INDUSTRIAL MOTION GROUP

SIZE **PTI**

DWG. NO.

WEIGHT	5.04 LBS
MATERIAL	SEE BOM
COATING	SEE BOM
DRAWN	SEC 01/08/2025
CHECKED	KODS 01/10/2025
APPROVED	
<small>THIRD ANGLE PROJECTION</small>	
<small>PROPRIETARY AND CONFIDENTIAL</small> <small>THE INFORMATION CONTAINED IN THIS DRAWING IS THE SOLE PROPERTY OF SOLVE IMG. ANY REPRODUCTION IN PART OR AS A WHOLE WITHOUT THE WRITTEN PERMISSION OF SOLVE IMG IS PROHIBITED.</small>	

3	M6 ZERK	STEEL	ZINC PLATED	1
2	UC210-32	BEARING STEEL	N/A	1
1	FB210	CAST IRON	POWDER COAT	1
ITEM NO.	PART NUMBER	MATERIAL	COATING	QTY.

DATE	BY	REVISION DESCRIPTION	REV
ITEM DESCRIPTION: FB210-32U			SCALE 1:8
			REV -

9 8 7 6 5 4 3 2 1

A B C D E F G