

9 8 7 6 5 4 3 2 1

G F E D C B A

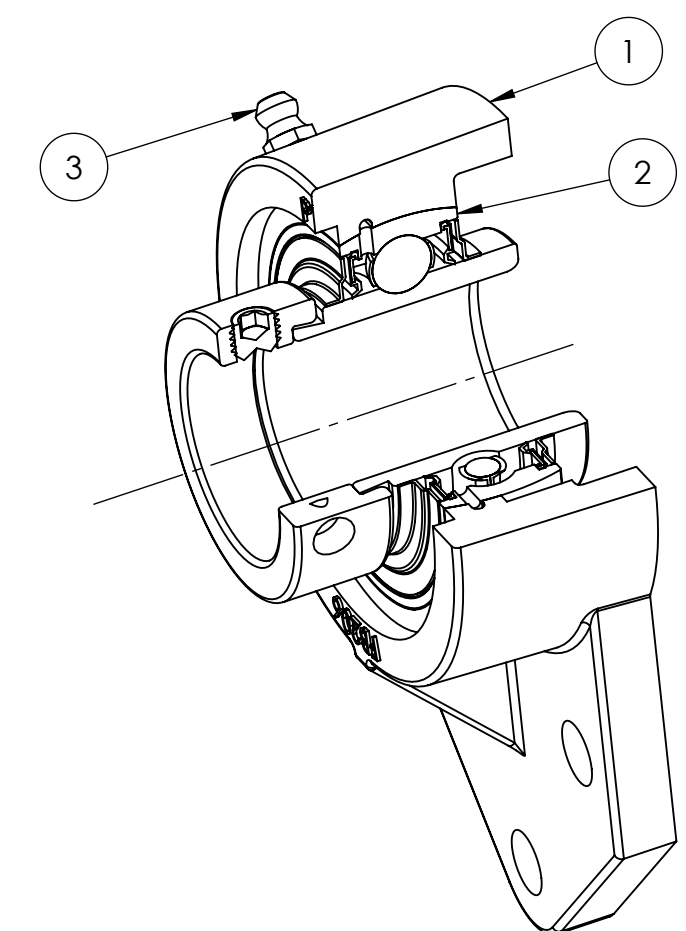
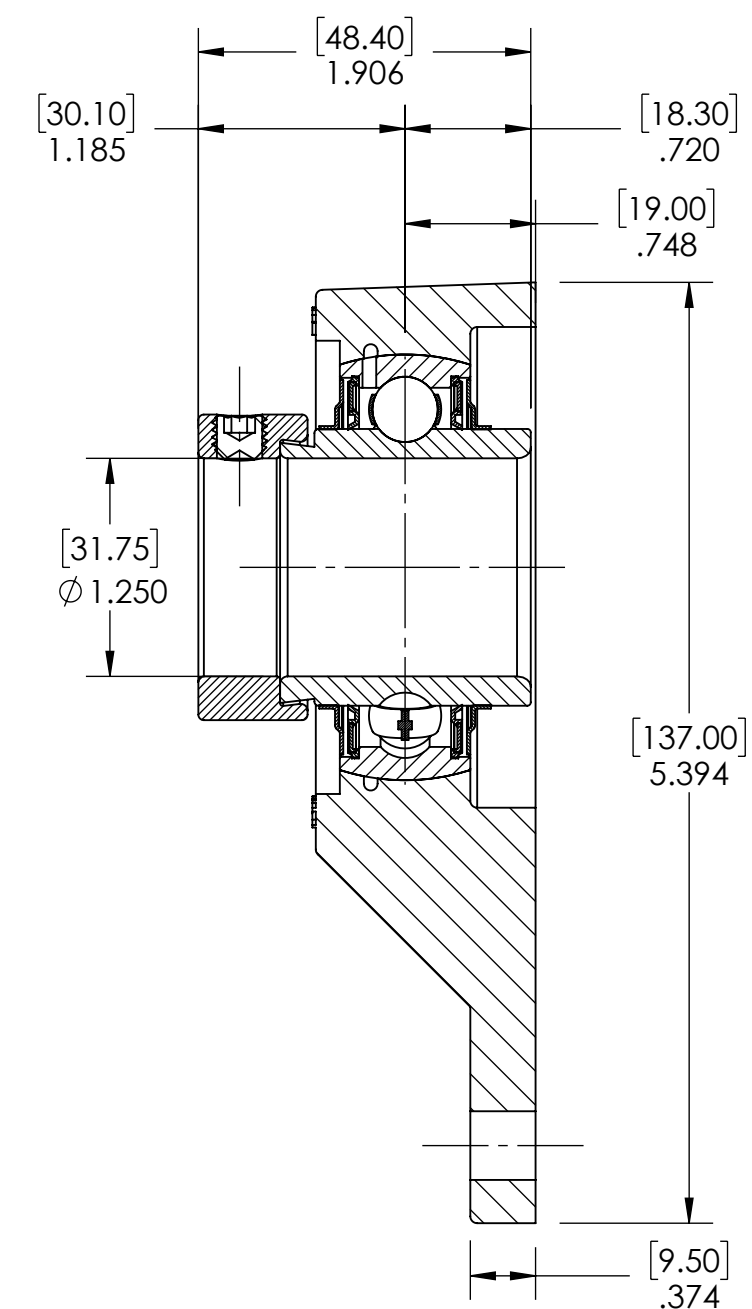
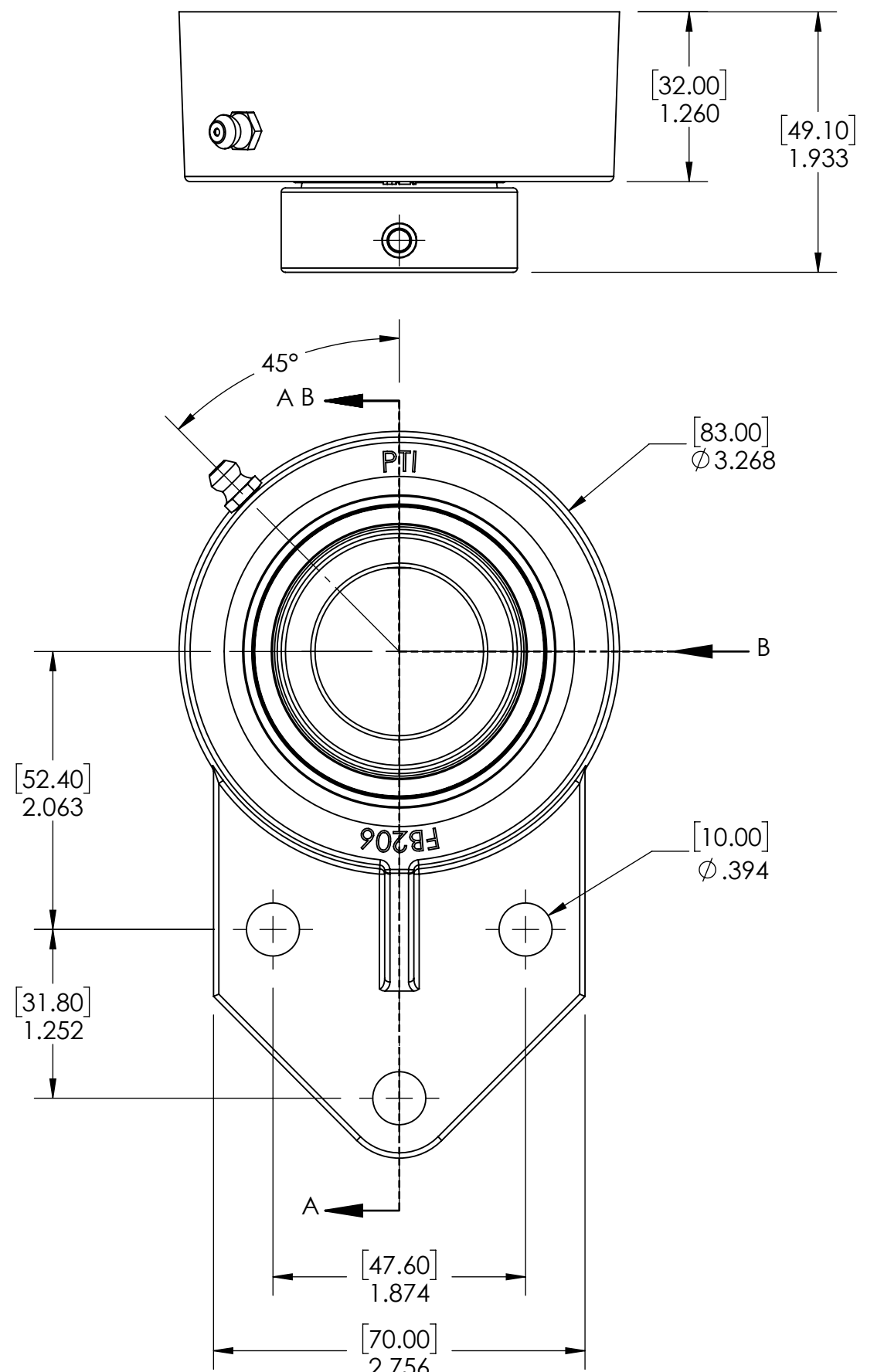

3	M6 ZERK	STEEL	ZINC PLATED	1
2	HC206-20	BEARING STEEL	N/A	1
1	FB206	CAST IRON	POWDER COAT	1
ITEM NO.	PART NUMBER	MATERIAL	COATING	QTY.

SPECIFICATIONS		WEIGHT	
UNITS:	IN (mm)		2.24 LBS
LOAD RATINGS	C: 4,300 LBS Co: 2,500 LBS	MATERIAL	SEE BOM
SPEED RATING	5300 RPM	COATING	SEE BOM
GREASE TYPE	NLGI #2	DRAWN	SEC 01/08/2025
GREASE FILL	40%	CHECKED	KODS 01/09/2025
OPERATING TEMP	10°F - 200°F	APPROVED	
SEAL TYPE	B-TYPE	THIRD ANGLE PROJECTION	
INTERNAL CLEARANCE	C3		
TORQUE SETTING ON SET SCREWS			



PROPRIETARY AND CONFIDENTIAL
THE INFORMATION CONTAINED IN THIS DRAWING IS THE SOLE PROPERTY OF SOLVE IMG. ANY REPRODUCTION IN PART OR AS A WHOLE WITHOUT THE WRITTEN PERMISSION OF SOLVE IMG IS PROHIBITED.

DATE	BY	REVISION DESCRIPTION	REV
ITEM DESCRIPTION: FB206-20A			SCALE 1:10
			REV -

9 8 7 6 5 4 3 2 1

A B C D E F G