

9 8 7 6 5 4 3 2 1

G F E D C B A

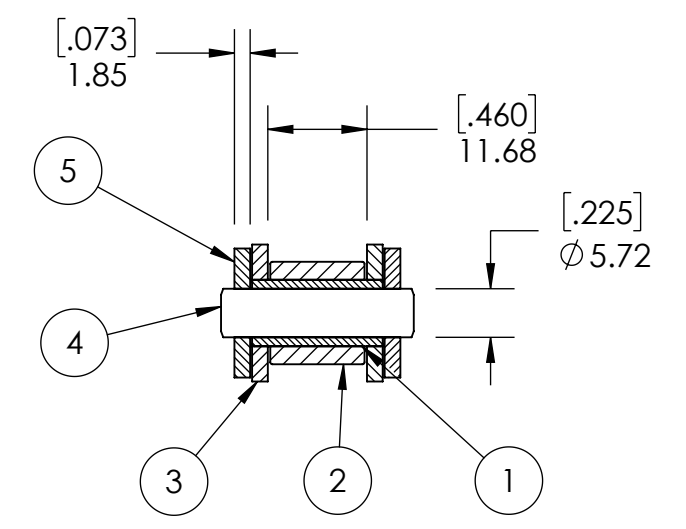
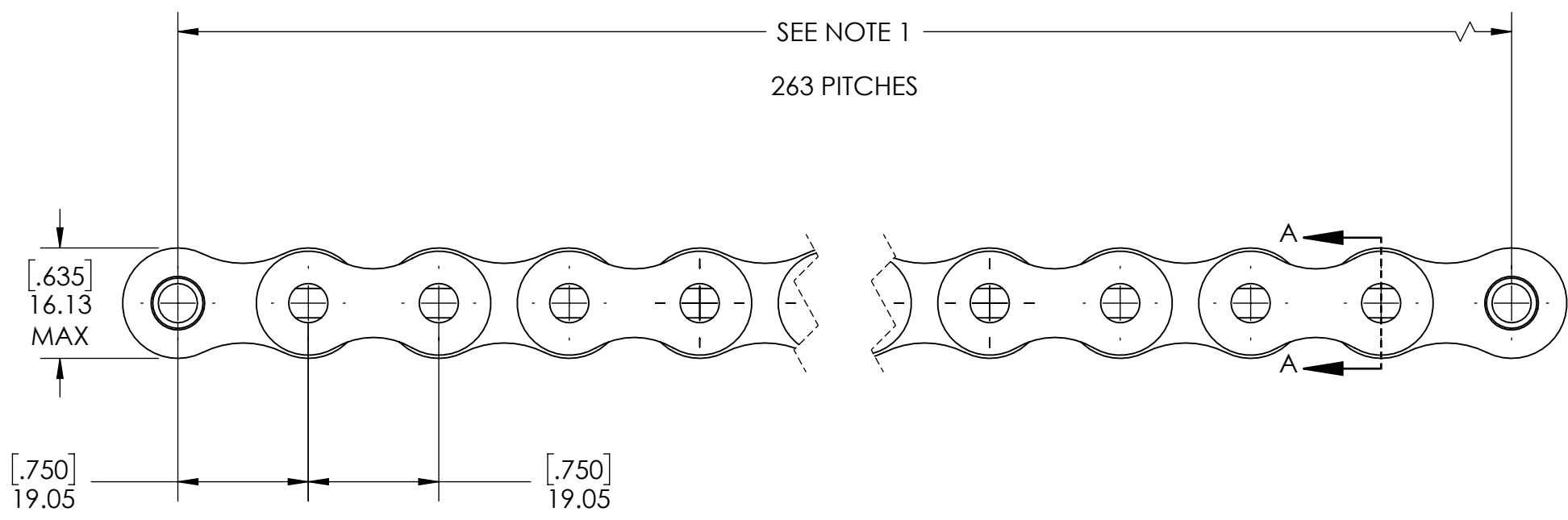
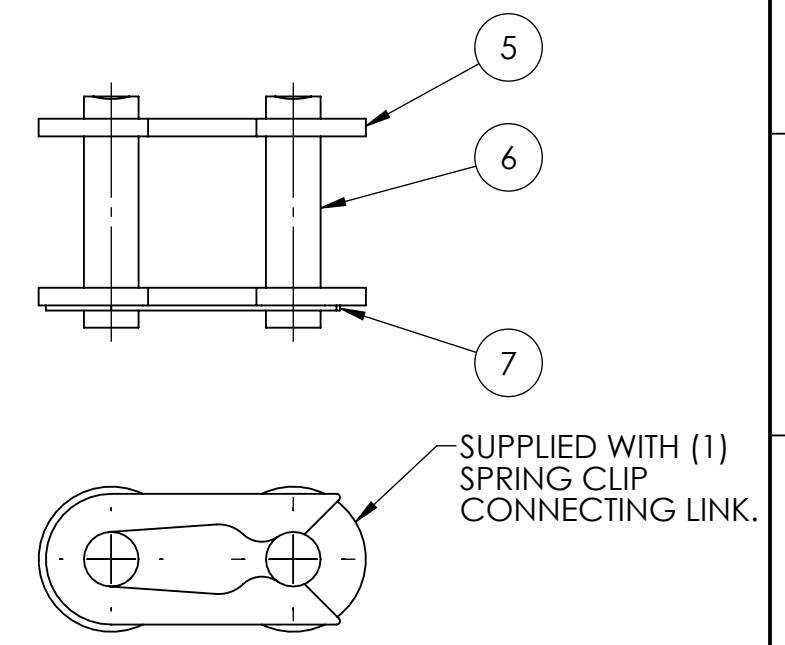
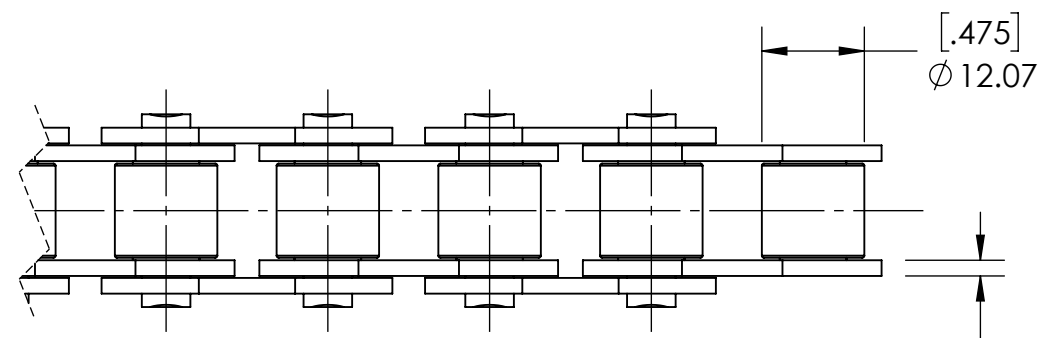
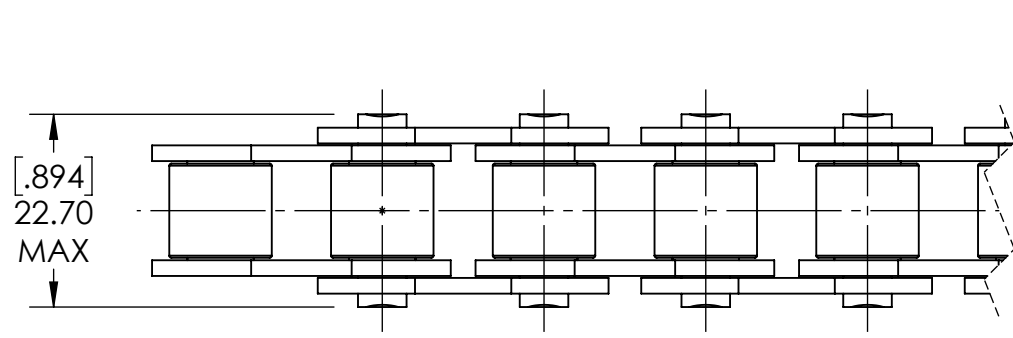

SECTION A-A

NOTES:  
1. SUPPLIED IN LENGTHS OF 5 METERS. ACTUAL LENGTH IS 5030 mm.

CHAINS SPECIFICATIONS	
UNITS	mm (INCH)
CHAIN NO.	12B
PITCH	0.75 IN
ROLLER DIAMETER	12.07 mm
INNER WIDTH	11.68 mm
AVERAGE ULTIMATE TENSILE STRENGTH	4158.97 LBS
CONNECTING LINK TYPE	SPRING CLIP
PIN CONSTRUCTION	SOLID
PIN RETENTION	RIVETED
INDUSTRY STANDARD	ISO 606

**SOLVE** INDUSTRIAL MOTION GROUP  
**PTI**  
 DWG. NO.

WEIGHT	12.87 LBS
MATERIAL	SEE BOM
COATING	ANTI-RUST OIL
DRAWN	PT 06/17/2025
CHECKED	SEC 07/24/2025
APPROVED	

ITEM NO.	PART NUMBER	MATERIAL	COATING
7	E12BSS SPRING CLIP	STAINLESS STEEL	N/A
6	E12B-1SS CONNECTING LINK PIN	STAINLESS STEEL	N/A
5	E12BSS OUTER PLATE	STAINLESS STEEL	N/A
4	E12B-1SSRIV PIN	STAINLESS STEEL	N/A
3	E12BSS INNER PLATE	STAINLESS STEEL	N/A
2	E12BSS ROLLER	STAINLESS STEEL	N/A
1	E12BSS BUSHING	STAINLESS STEEL	N/A

DATE	BY	REVISION DESCRIPTION	REV
ITEM DESCRIPTION: E12B-1SSRIV			SCALE 1:1
			REV -

9 8 7 6 5 4 3 2 1

A B C D E F G