

9 8 7 6 5 4 3 2 1

G G

F F

E E

D D

C C

B B

A A

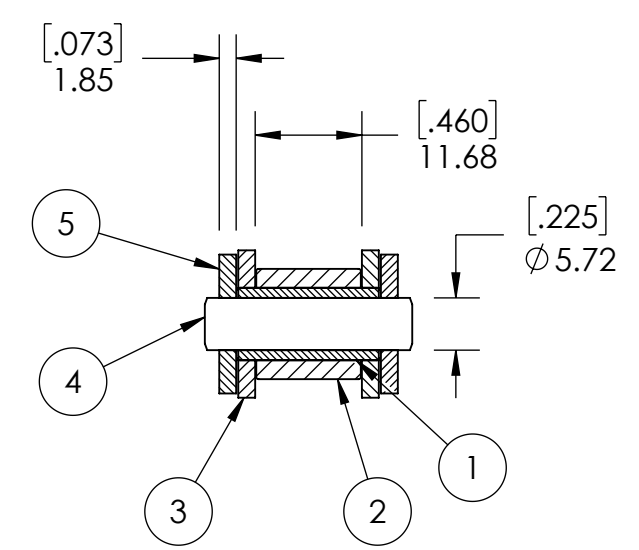
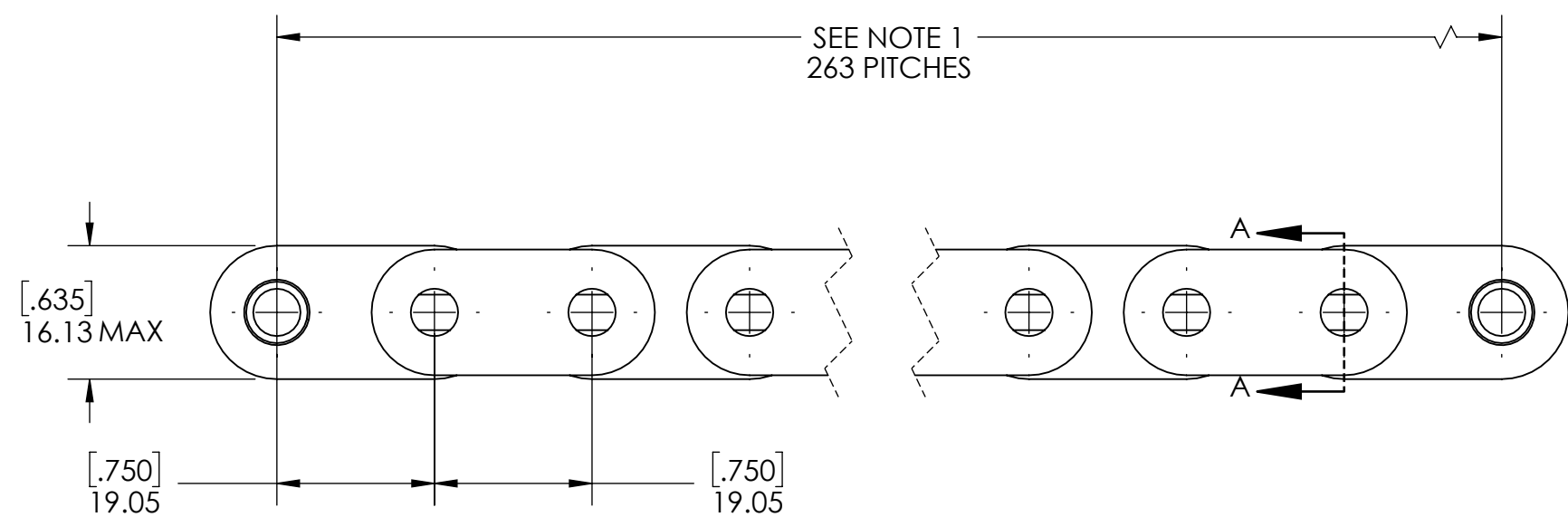
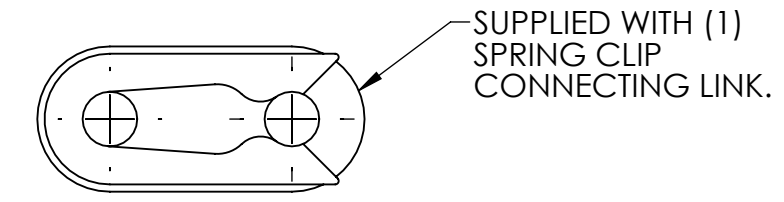
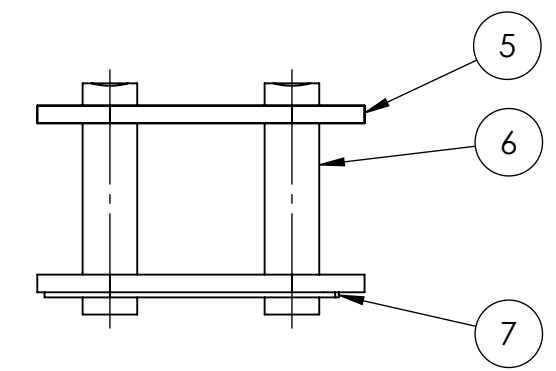
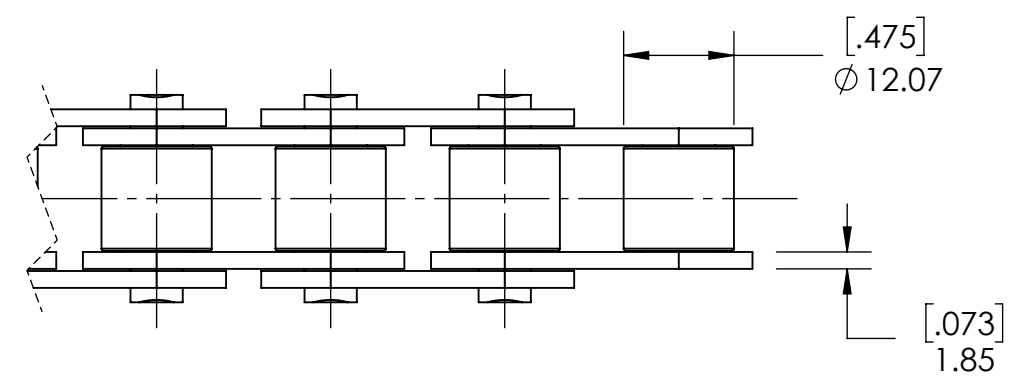
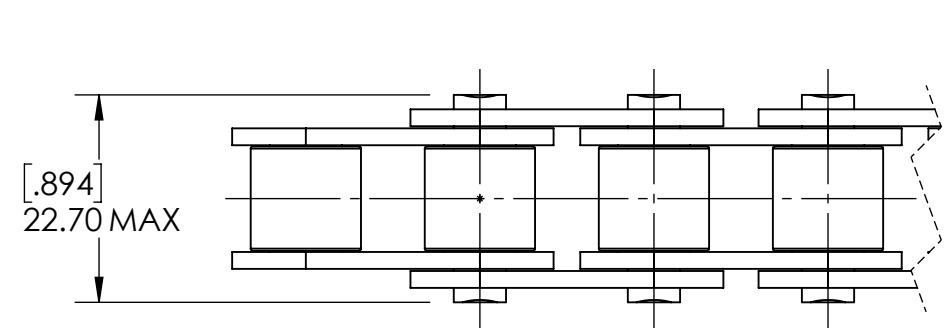

SECTION A-A

NOTES:
1. SUPPLIED IN LENGTHS OF 5 METERS. ACTUAL LENGTH IS 5030 mm.

CHAINS SPECIFICATIONS	
UNITS	mm [INCH]
CHAIN NO.	12B
PITCH	0.75 IN
ROLLER DIAMETER	12.07 mm
INNER WIDTH	11.68 mm
AVERAGE ULTIMATE TENSILE STRENGTH	6519.46 LBS
CONNECTING LINK TYPE	SPRING CLIP
PIN CONSTRUCTION	SOLID
PIN RETENTION	RIVETED
INDUSTRY STANDARD	ISO 606



WEIGHT	14.64 LBS
MATERIAL	SEE BOM
COATING	ANTI-RUST OIL
DRAWN	SEC 06/24/2025
CHECKED	PT 07/01/2025
APPROVED	
THIRD ANGLE PROJECTION	

ITEM NO.	PART NUMBER	MATERIAL	COATING
7	E12B SPRING CLIP	STEEL	N/A
6	E12B-1GL CONNECTING LINK PIN	STEEL	N/A
5	E12BGL OUTER PLATE	STEEL	N/A
4	E12B-1GLRIV PIN	STEEL	N/A
3	E12BGL INNER PLATE	STEEL	N/A
2	E12BGL ROLLER	STEEL	N/A
1	E12BGL BUSHING	STEEL	N/A

DATE	BY	REVISION DESCRIPTION	REV
ITEM DESCRIPTION: E12B-1GLRIV			SCALE 1:1
			REV -

9 8 7 6 5 4 3 2 1