

9 8 7 6 5 4 3 2 1

G
F
E
D
C
B
A

G
F
E
D
C
B
A

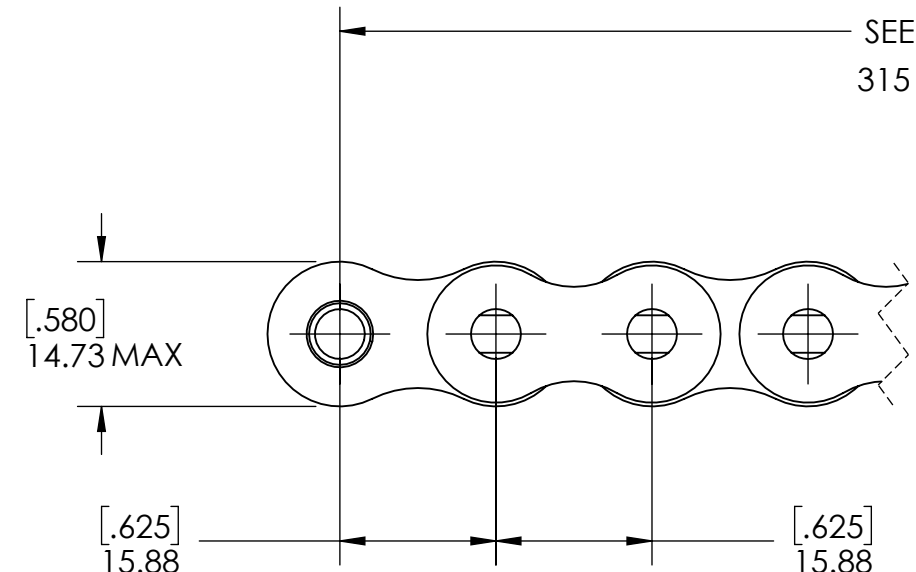
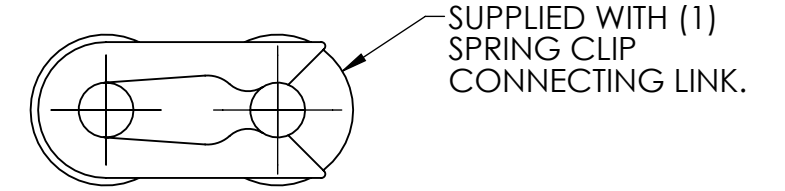
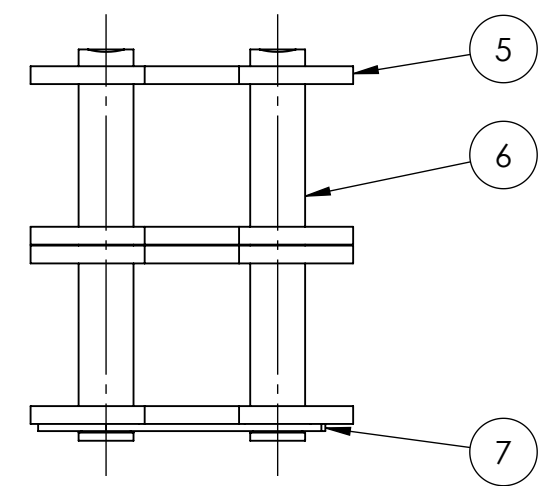
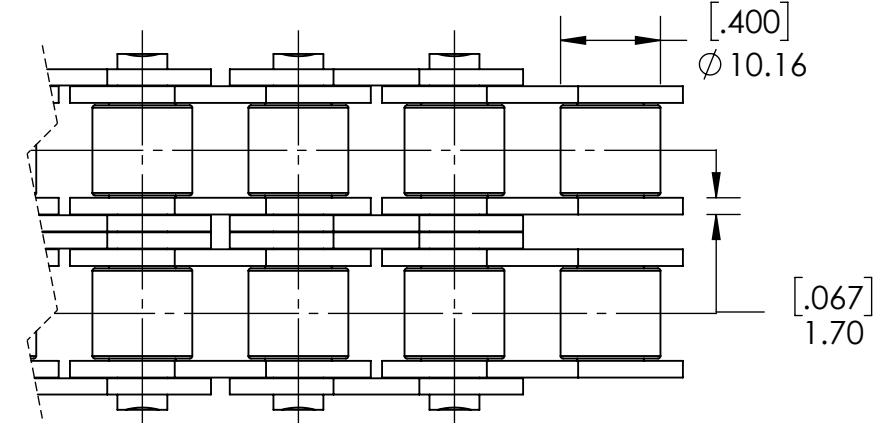
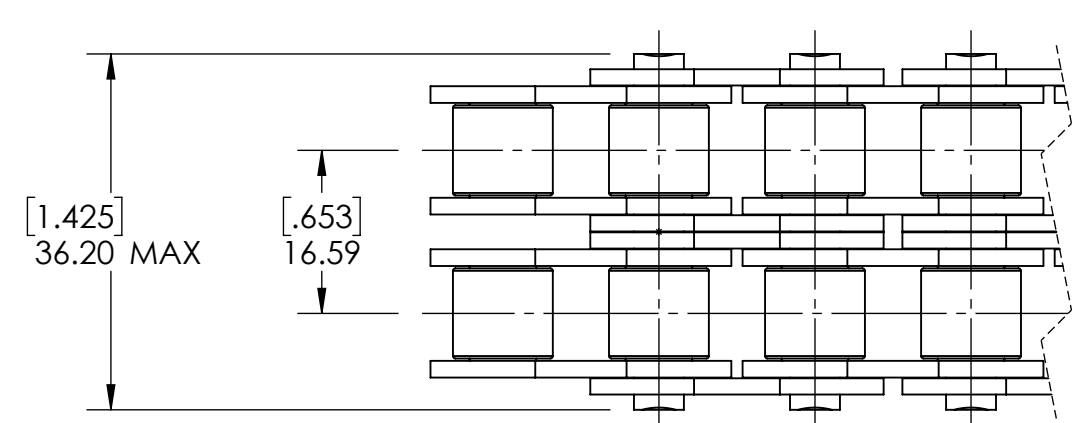

SEE NOTE 1
315 PITCHES

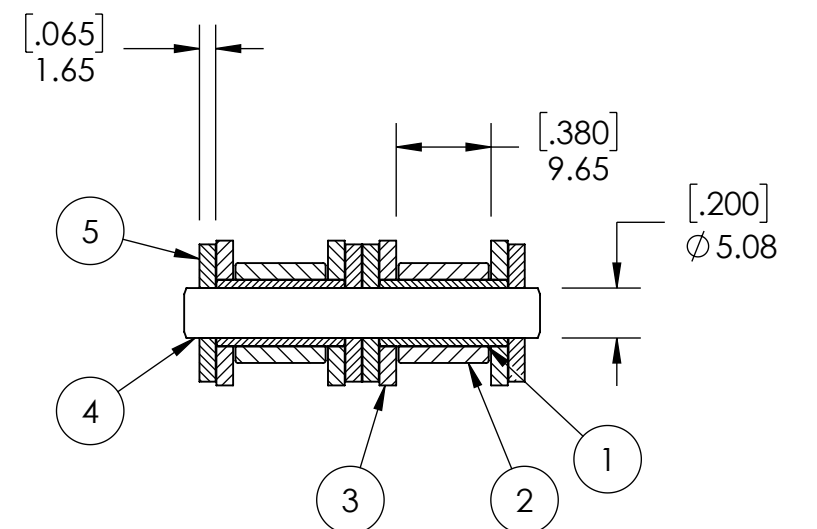
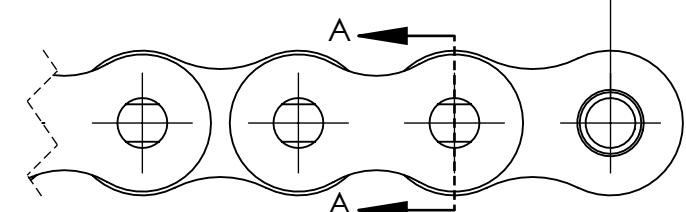

SECTION A-A

NOTES:
1. SUPPLIED IN LENGTHS OF 5 METERS. ACTUAL LENGTH IS 5017 mm.

CHAINS SPECIFICATIONS		WEIGHT	
UNITS	mm (INCH)		21.69 LBS
CHAIN NO.	10B	MATERIAL	SEE BOM
PITCH	0.625 IN	COATING	ANTI-RUST OIL
ROLLER DIAMETER	10.16 mm	DRAWN	SEC 07/14/2025
INNER WIDTH	9.65 mm	CHECKED	PT 07/15/2025
AVERAGE ULTIMATE TENSILE STRENGTH	6519.46 LBS	APPROVED	
CONNECTING LINK TYPE	SPRING CLIP	THIRD ANGLE PROJECTION	
PIN CONSTRUCTION	SOLID		
PIN RETENTION	RIVETED		
INDUSTRY STANDARD	ISO 606		



ITEM NO.	PART NUMBER	MATERIAL	COATING
7	E10BSS SPRING CLIP	STAINLESS STEEL	N/A
6	E10B-2SS CONNECTING LINK PIN	STAINLESS STEEL	N/A
5	E10BSS OUTER PLATE	STAINLESS STEEL	N/A
4	E10B-2SSRIV PIN	STAINLESS STEEL	N/A
3	E10BSS INNER PLATE	STAINLESS STEEL	N/A
2	E10BSS ROLLER	STAINLESS STEEL	N/A
1	E10BSS BUSHING	STAINLESS STEEL	N/A

DATE	BY	REVISION DESCRIPTION	REV
ITEM DESCRIPTION: E10B-2SSRIV			SCALE 1:1
			REV -

9 8 7 6 5 4 3 2 1