

9 8 7 6 5 4 3 2 1

G F E D C B A

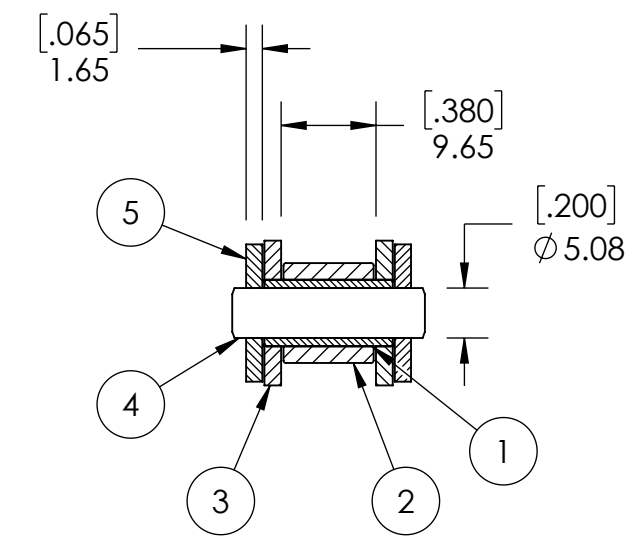
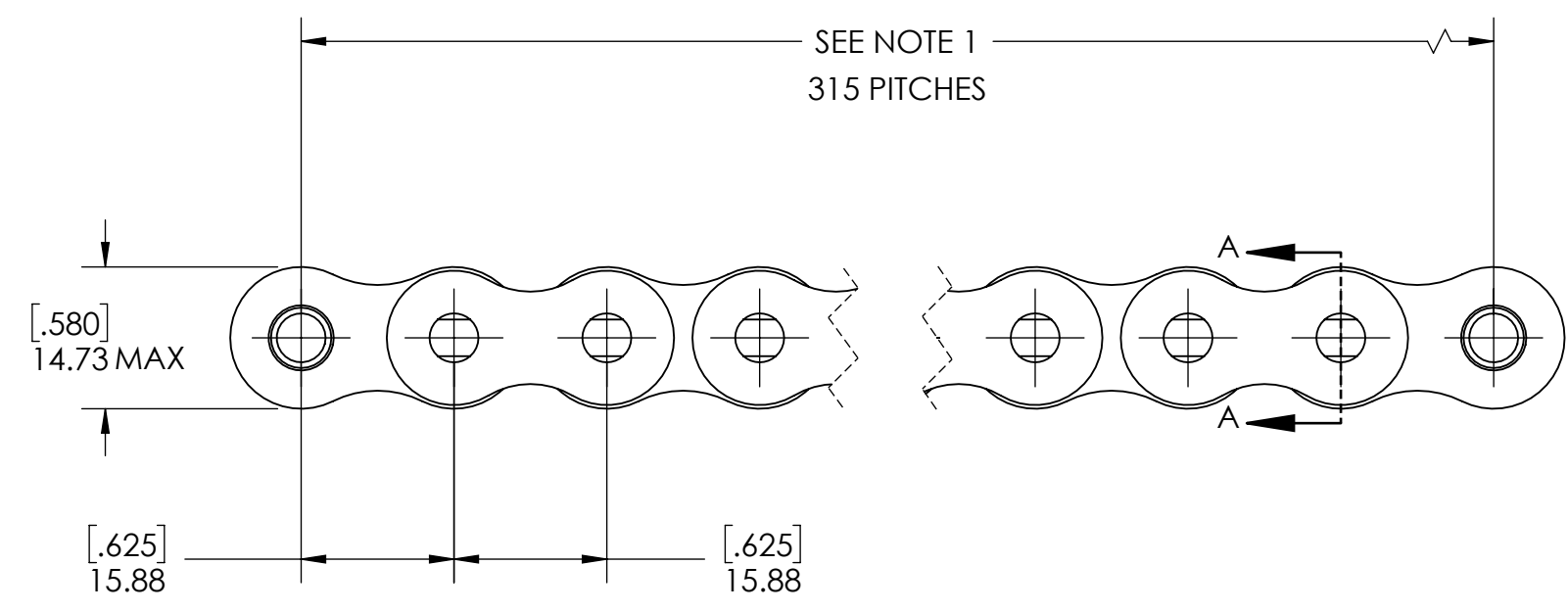
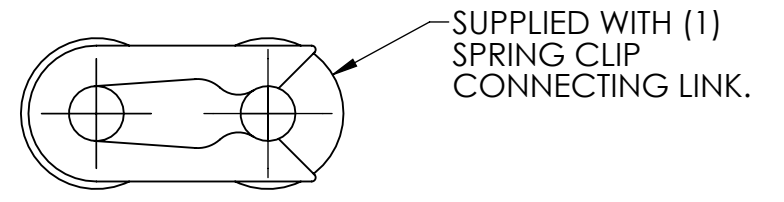
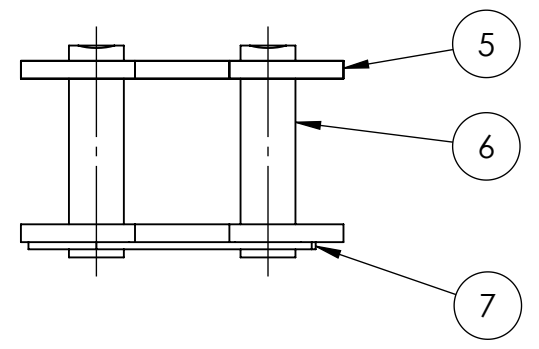
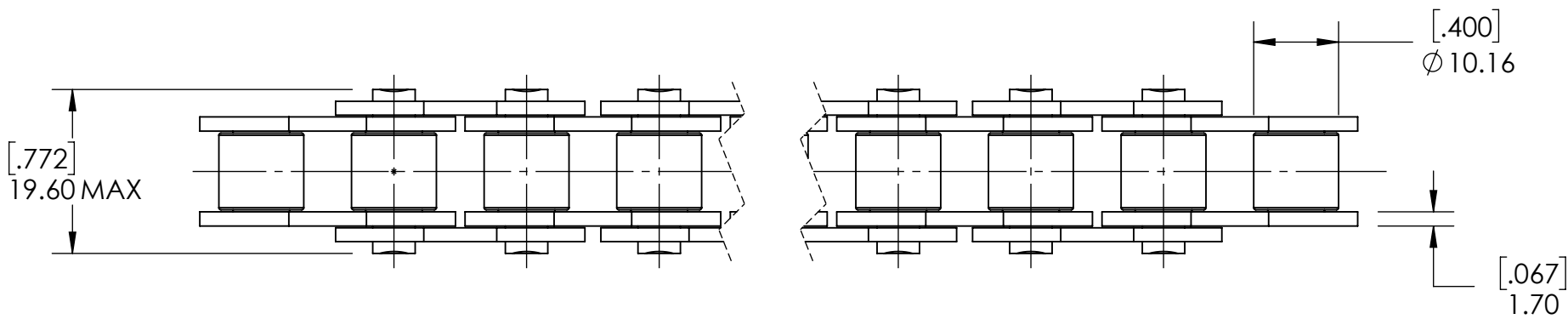

SECTION A-A

7	E10BSS SPRING CLIP	STAINLESS STEEL	N/A
6	E10B-1SS CONNECTING LINK PIN	STAINLESS STEEL	N/A
5	E10BSS OUTER PLATE	STAINLESS STEEL	N/A
4	E10B-1SSRIV PIN	STAINLESS STEEL	N/A
3	E10BSS INNER PLATE	STAINLESS STEEL	N/A
2	E10BSS ROLLER	STAINLESS STEEL	N/A
1	E10BSS BUSHING	STAINLESS STEEL	N/A
ITEM NO.	PART NUMBER	MATERIAL	COATING

CHAINS SPECIFICATIONS	
UNITS	mm (INCH)
CHAIN NO.	10B
PITCH	0.625 IN
ROLLER DIAMETER	10.16 mm
INNER WIDTH	9.65 mm
AVERAGE ULTIMATE TENSILE STRENGTH	3259.73 LBS
CONNECTING LINK TYPE	SPRING CLIP
PIN CONSTRUCTION	SOLID
PIN RETENTION	RIVETED
INDUSTRY STANDARD	ISO 606

**SOLVE**  
INDUSTRIAL MOTION GROUP

SIZE **PTI**

DWG. NO.

WEIGHT	10.4 LBS
MATERIAL	SEE BOM
COATING	ANTI-RUST OIL
DRAWN	SEC 07/14/2025
CHECKED	PT 07/15/2025
APPROVED	

DATE	BY	REVISION DESCRIPTION	REV
		ITEM DESCRIPTION: E10B-1SSRIV	SCALE 1:1
			REV -

NOTES:  
1. SUPPLIED IN LENGTHS OF 5 METERS. ACTUAL LENGTH IS 5017 mm.

9 8 7 6 5 4 3 2 1

A B C D E F G