

9 8 7 6 5 4 3 2 1

G
F
E
D
C
B
A

G
F
E
D
C
B
A

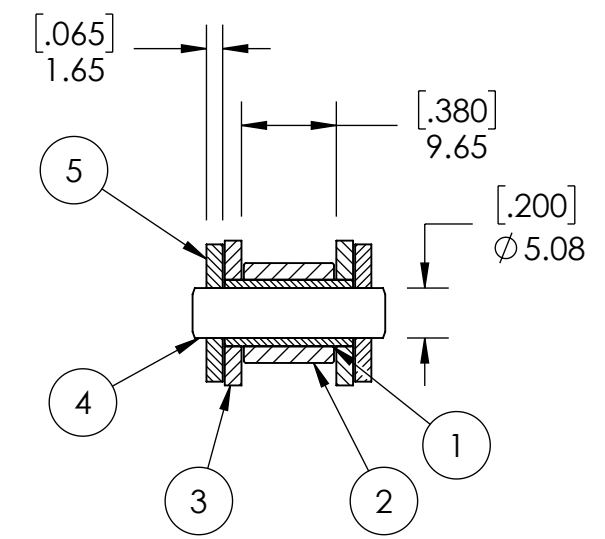
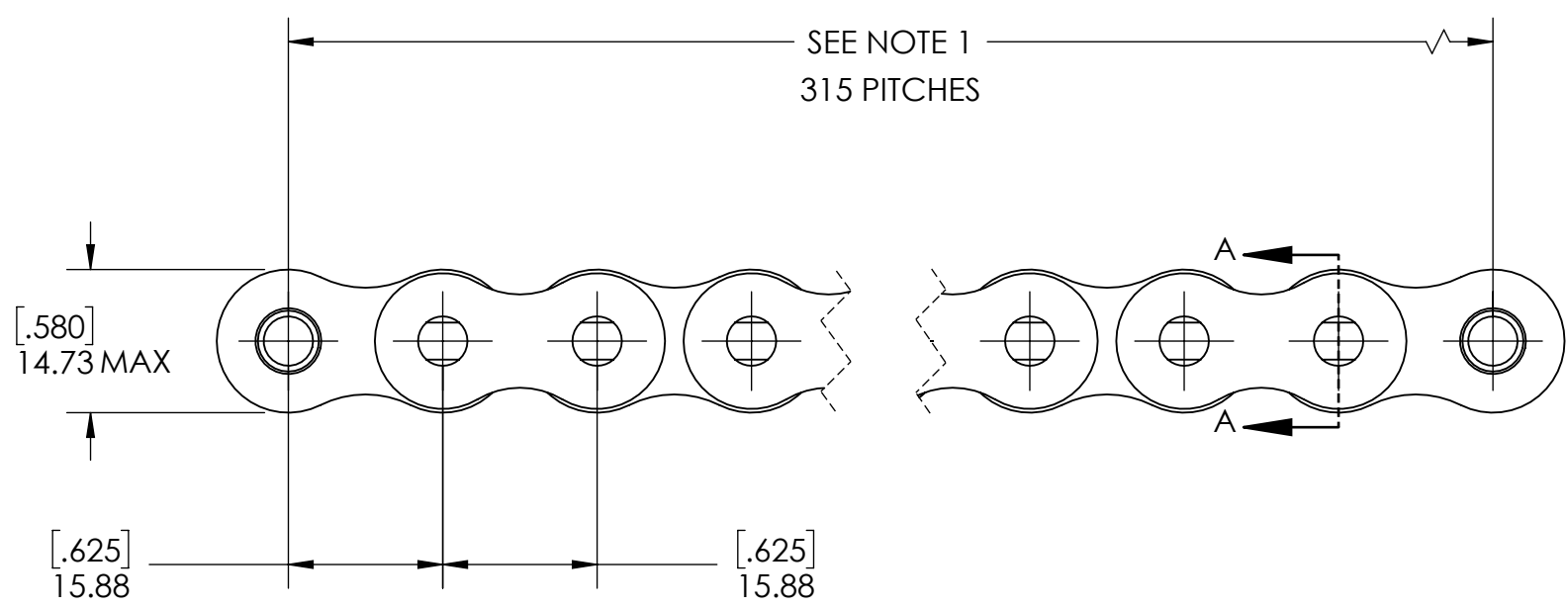
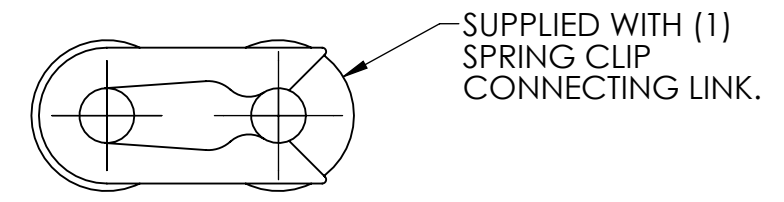
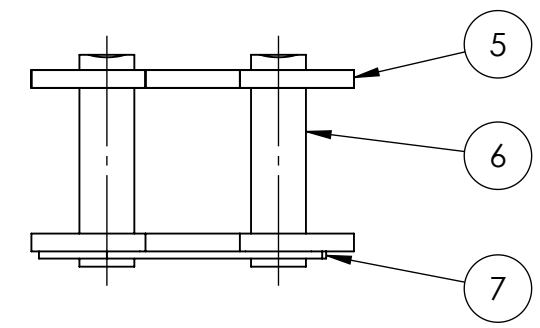
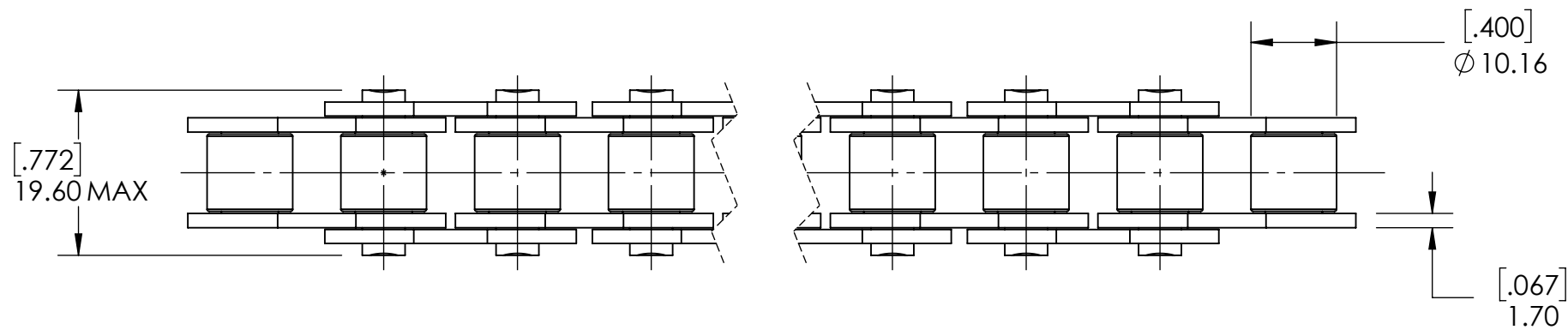

SECTION A-A

ITEM NO.	PART NUMBER	MATERIAL	COATING
7	E10B SPRING CLIP	STEEL	N/A
6	E10B-1 CONNECTING LINK PIN	STEEL	N/A
5	E10B OUTER PLATE	STEEL	N/A
4	E10B-1RIV PIN	STEEL	N/A
3	E10B INNER PLATE	STEEL	N/A
2	E10B ROLLER	STEEL	N/A
1	E10B BUSHING	STEEL	N/A

CHAINS SPECIFICATIONS	
UNITS	mm (INCH)
CHAIN NO.	10B
PITCH	0.625 IN
ROLLER DIAMETER	10.16 mm
INNER WIDTH	9.65 mm
AVERAGE ULTIMATE TENSILE STRENGTH	6182.25 LBS
CONNECTING LINK TYPE	SPRING CLIP
PIN CONSTRUCTION	SOLID
PIN RETENTION	RIVETED
INDUSTRY STANDARD	ISO 606

SOLVE
INDUSTRIAL MOTION GROUP

SIZE **PTI**

DWG. NO.

WEIGHT	10.29 LBS
MATERIAL	SEE BOM
COATING	ANTI-RUST OIL
DRAWN	SEC 07/14/2025
CHECKED	PT 07/15/2025
APPROVED	

DATE	BY	REVISION DESCRIPTION	REV
ITEM DESCRIPTION: E10B-1RIV			SCALE 1:1
			REV -

NOTES:
1. SUPPLIED IN LENGTHS OF 5 METERS. ACTUAL LENGTH IS 5017 mm.

9 8 7 6 5 4 3 2 1