

9 8 7 6 5 4 3 2 1

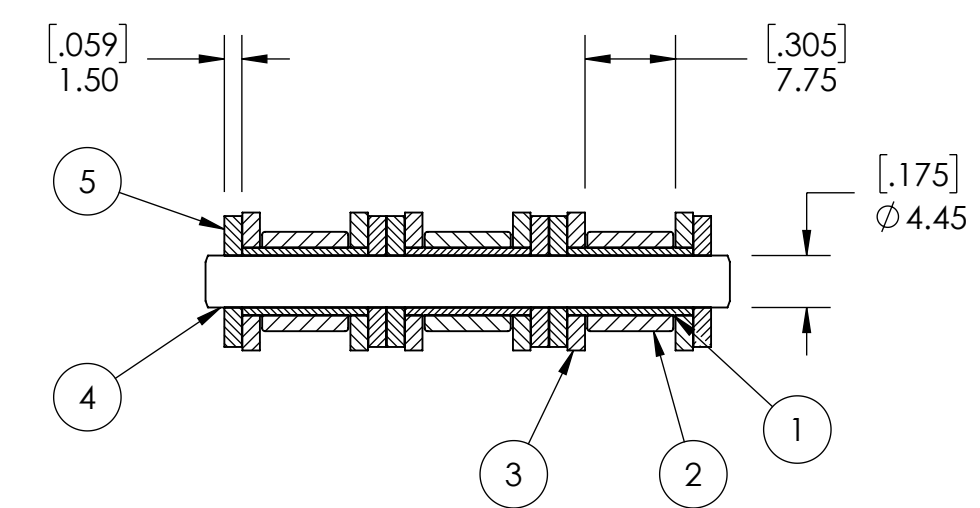
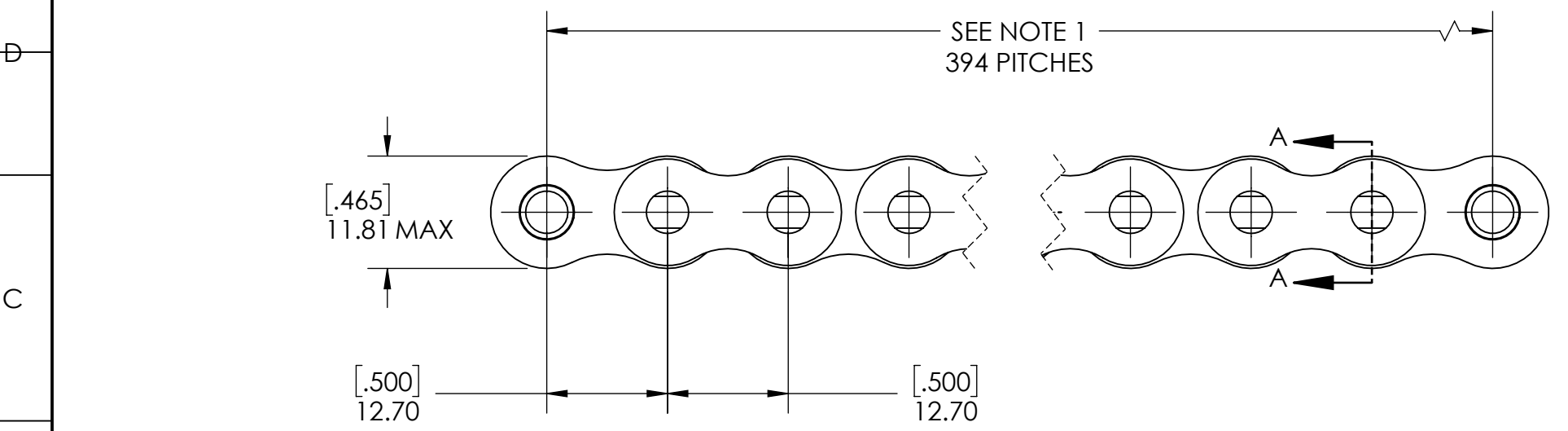
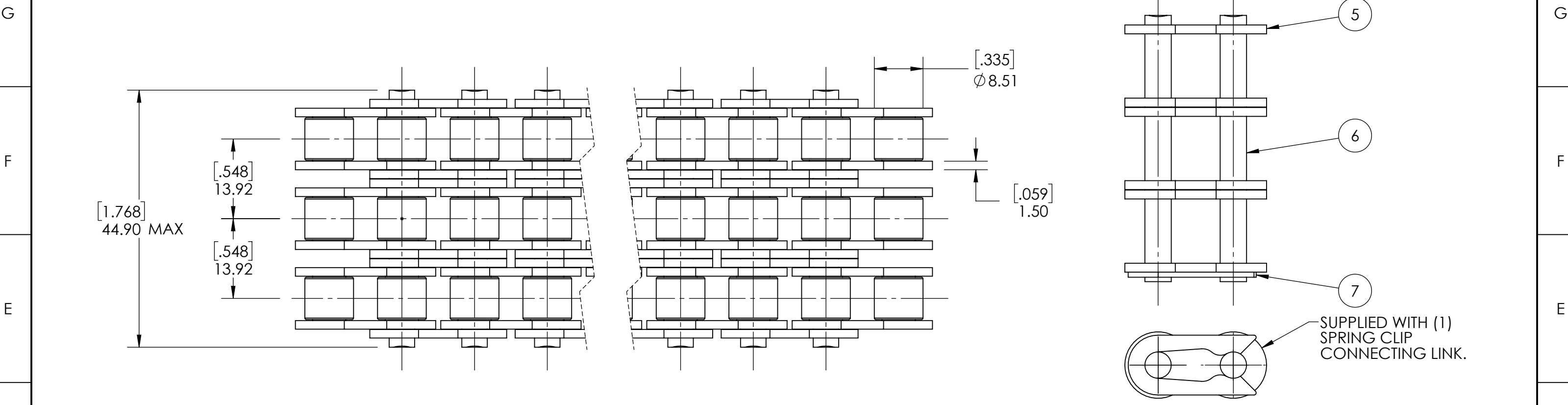

SECTION A-A

7	E08B SPRING CLIP	STEEL	N/A
6	E08B-3 CONNECTING LINK PIN	STEEL	N/A
5	E08B OUTER PLATE	STEEL	N/A
4	E08B-3RIV PIN	STEEL	N/A
3	E08B INNER PLATE	STEEL	N/A
2	E08B ROLLER	STEEL	N/A
1	E08B BUSHING	STEEL	N/A
ITEM NO.	PART NUMBER	MATERIAL	COATING

NOTES:
1. SUPPLIED IN LENGTHS OF 5 METERS. ACTUAL LENGTH IS 5017 mm.

CHAINS SPECIFICATIONS		WEIGHT	
UNITS	mm (INCH)	22.46 LBS	
CHAIN NO.	081B	MATERIAL	SEE BOM
PITCH	0.5 IN	COATING	ANTI-RUST OIL
ROLLER DIAMETER	8.51 mm	DRAWN	SEC 07/14/2025
INNER WIDTH	7.75 mm	CHECKED	PT 07/15/2025
AVERAGE ULTIMATE TENSILE STRENGTH	12993.96 LBS	APPROVED	
CONNECTING LINK TYPE	SPRING CLIP	THIRD ANGLE PROJECTION	
PIN CONSTRUCTION	SOLID		
PIN RETENTION	RIVETED		
INDUSTRY STANDARD	ISO 606		



DWG. NO. PROPRIETARY AND CONFIDENTIAL
THE INFORMATION CONTAINED IN THIS DRAWING IS THE SOLE PROPERTY OF SOLVE IMG. ANY REPRODUCTION IN PART OR AS A WHOLE WITHOUT THE WRITTEN PERMISSION OF SOLVE IMG IS PROHIBITED.

DATE	BY	REVISION DESCRIPTION	REV
		ITEM DESCRIPTION: E08B-3RIV	SCALE 1:1
			REV -

9 8 7 6 5 4 3 2 1