

9 8 7 6 5 4 3 2 1

G
F
E
D
C
B
A

G
F
E
D
C
B
A

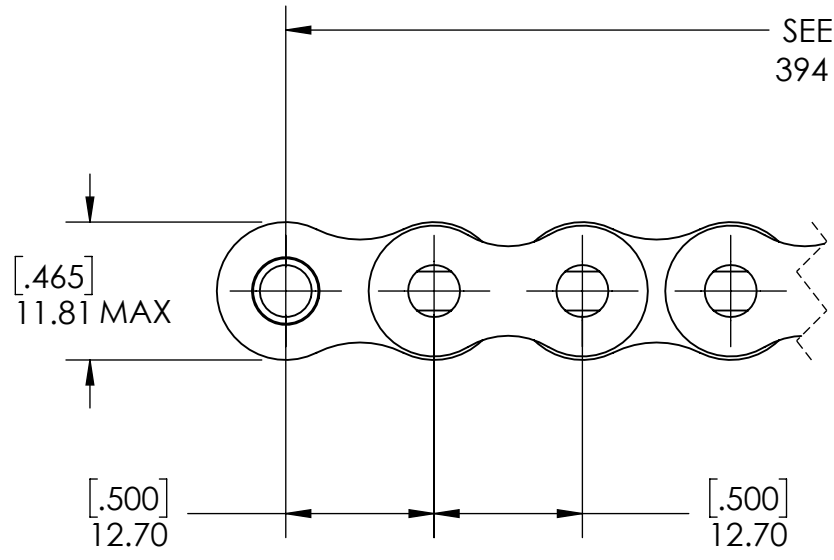
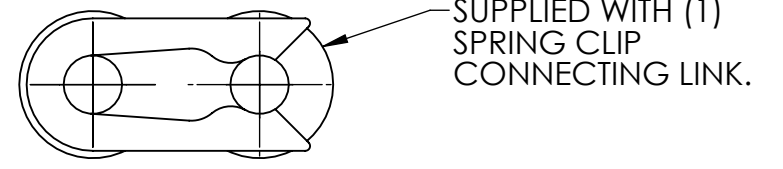
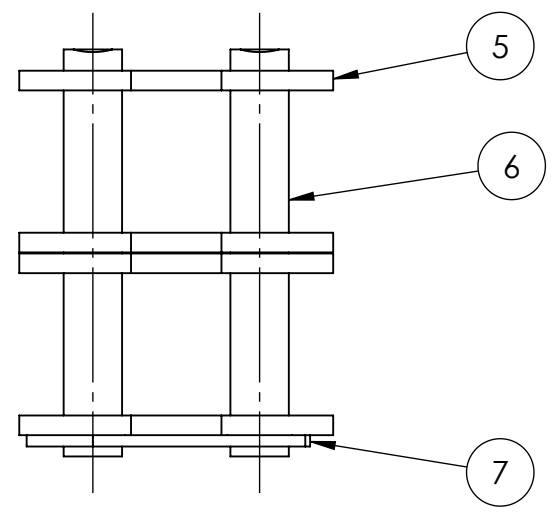
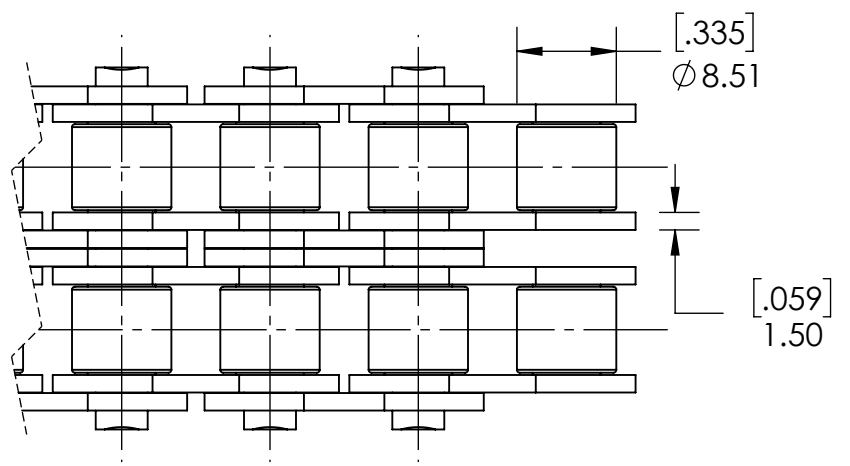
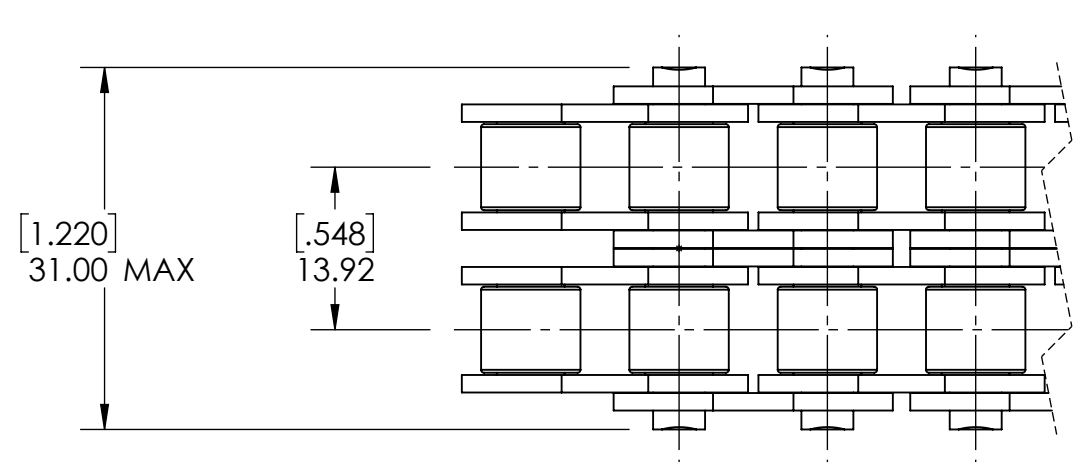

SEE NOTE 1
394 PITCHES

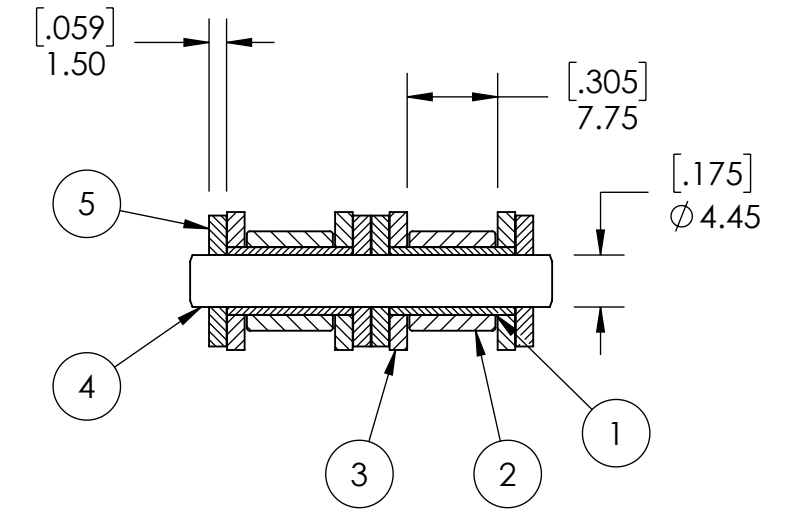
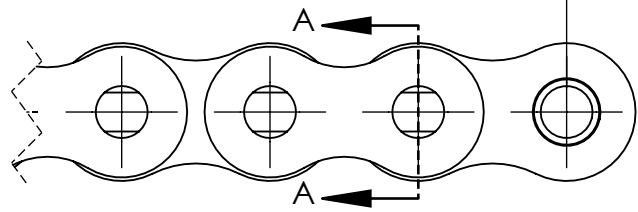

SECTION A-A

NOTES:
1. SUPPLIED IN LENGTHS OF 5 METERS. ACTUAL LENGTH IS 5017 mm.

CHAINS SPECIFICATIONS	
UNITS	mm (INCH)
CHAIN NO.	081B
PITCH	0.5 IN
ROLLER DIAMETER	8.51 mm
INNER WIDTH	7.75 mm
AVERAGE ULTIMATE TENSILE STRENGTH	8700.11 LBS
CONNECTING LINK TYPE	SPRING CLIP
PIN CONSTRUCTION	SOLID
PIN RETENTION	RIVETED
INDUSTRY STANDARD	ISO 606



WEIGHT	14.83 LBS
MATERIAL	SEE BOM
COATING	ANTI-RUST OIL
DRAWN	SEC 07/14/2025
CHECKED	PT 07/15/2025
APPROVED	
THIRD ANGLE PROJECTION	

ITEM NO.	PART NUMBER	MATERIAL	COATING
7	E08B SPRING CLIP	STEEL	N/A
6	E08B-2 CONNECTING LINK PIN	STEEL	N/A
5	E08B OUTER PLATE	STEEL	N/A
4	E08B-2RIV PIN	STEEL	N/A
3	E08B INNER PLATE	STEEL	N/A
2	E08B ROLLER	STEEL	N/A
1	E08B BUSHING	STEEL	N/A

DATE	BY	REVISION DESCRIPTION	REV
ITEM DESCRIPTION:			SCALE
E08B-2RIV			1:1
			REV
			-

9 8 7 6 5 4 3 2 1