

9 8 7 6 5 4 3 2 1

G
F
E
D
C
B
A

G
F
E
D
C
B
A

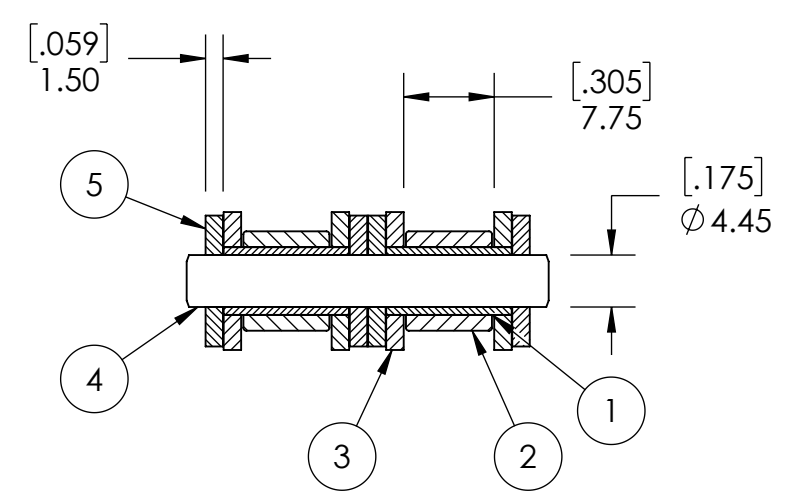
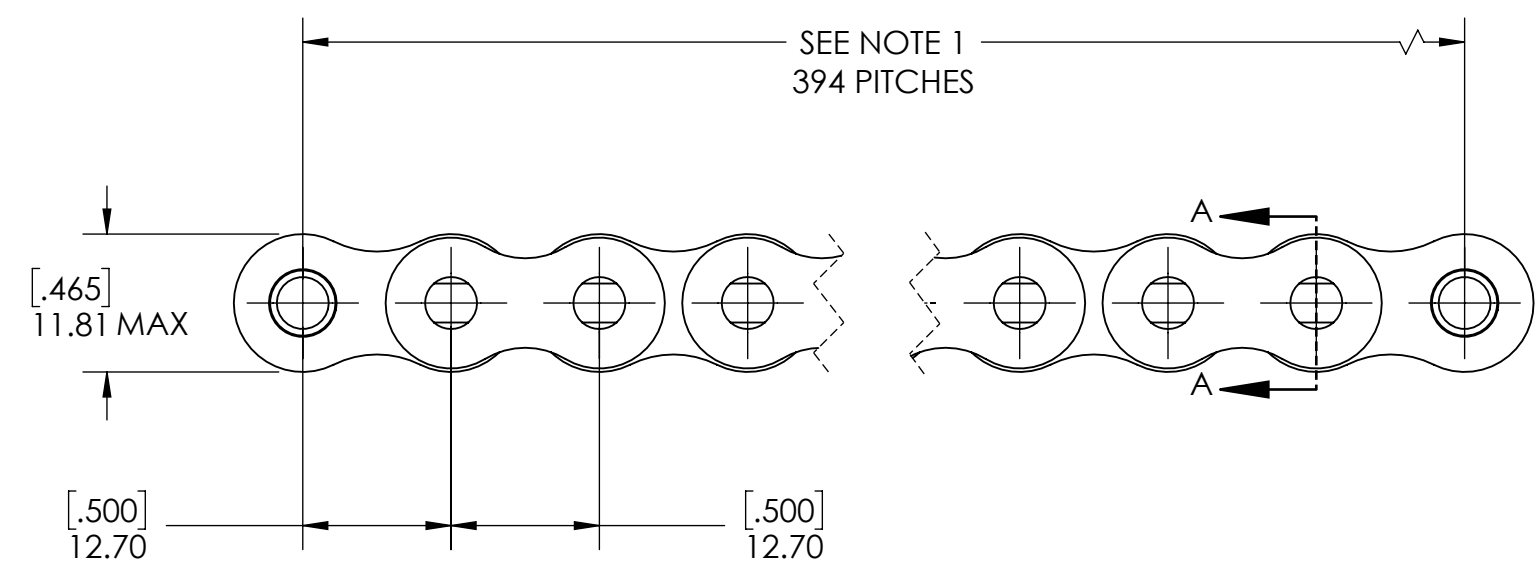
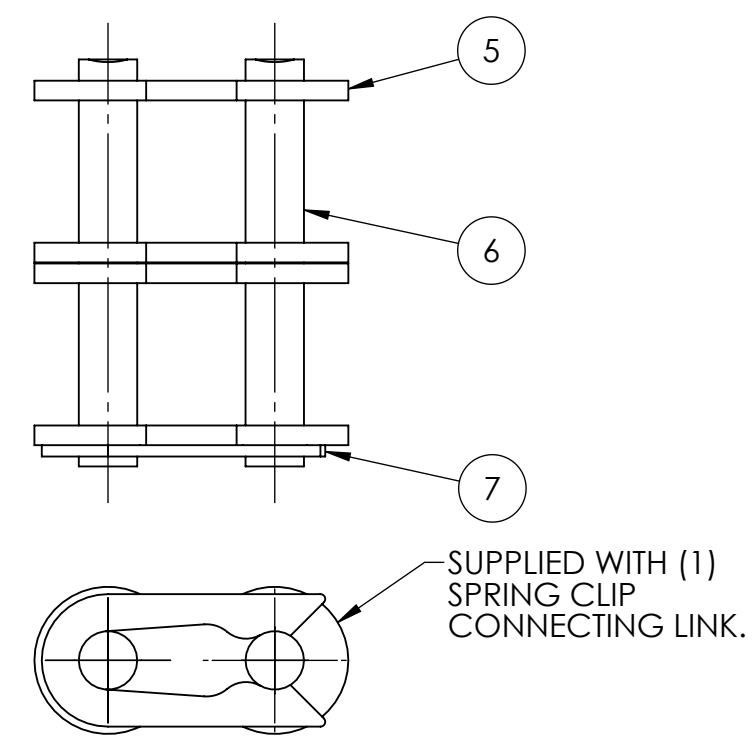
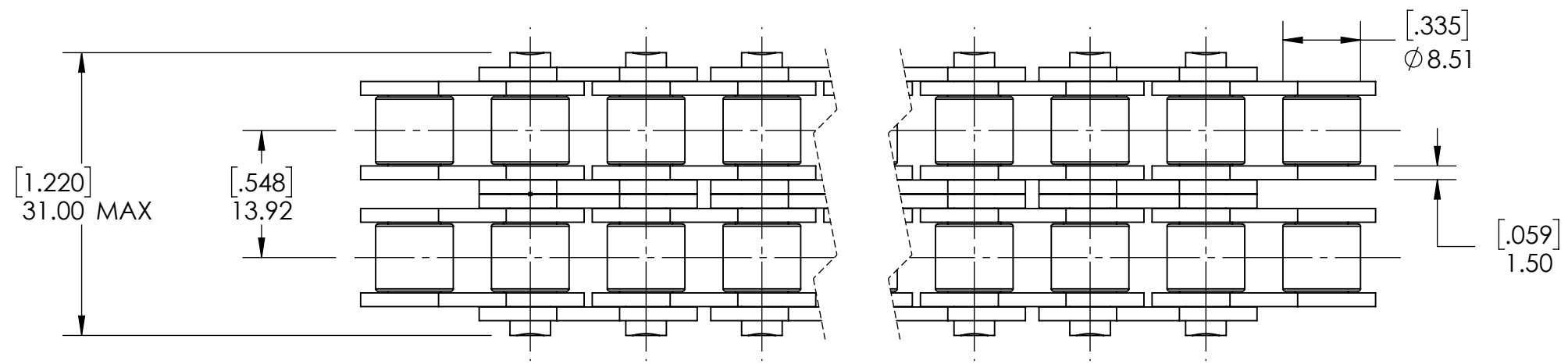

SECTION A-A

NOTES:
1. SUPPLIED IN LENGTHS OF 5 METERS. ACTUAL LENGTH IS 5017 mm.

CHAINS SPECIFICATIONS	
UNITS	mm (INCH)
CHAIN NO.	08B
PITCH	0.5 IN
ROLLER DIAMETER	8.51 mm
INNER WIDTH	7.75 mm
AVERAGE ULTIMATE TENSILE STRENGTH	0 LBS
CONNECTING LINK TYPE	SPRING CLIP
PIN CONSTRUCTION	SOLID
PIN RETENTION	RIVETED
INDUSTRY STANDARD	ISO 606

SOLVE INDUSTRIAL MOTION GROUP
PTI
 DWG. NO.

WEIGHT	14.83 LBS
MATERIAL	SEE BOM
COATING	ANTI-RUST OIL
DRAWN	SEC 07/14/2025
CHECKED	PT 07/15/2025
APPROVED	

ITEM NO.	PART NUMBER	MATERIAL	COATING
7	E08BNP SPRING CLIP	STEEL	NICKEL PLATED
6	E08B-2NP CONNECTING LINK PIN	STEEL	NICKEL PLATED
5	E08BNP OUTER PLATE	STEEL	NICKEL PLATED
4	E08B-2NPRIV PIN	STEEL	NICKEL PLATED
3	E08BNP INNER PLATE	STEEL	NICKEL PLATED
2	E08BNP ROLLER	STEEL	NICKEL PLATED
1	E08BNP BUSHING	STEEL	NICKEL PLATED

DATE	BY	REVISION DESCRIPTION	REV

ITEM DESCRIPTION: E08B-2NPRIV

SCALE: 1:1

9 8 7 6 5 4 3 2 1