

9 8 7 6 5 4 3 2 1

G G

F F

E E

D D

C C

B B

A A

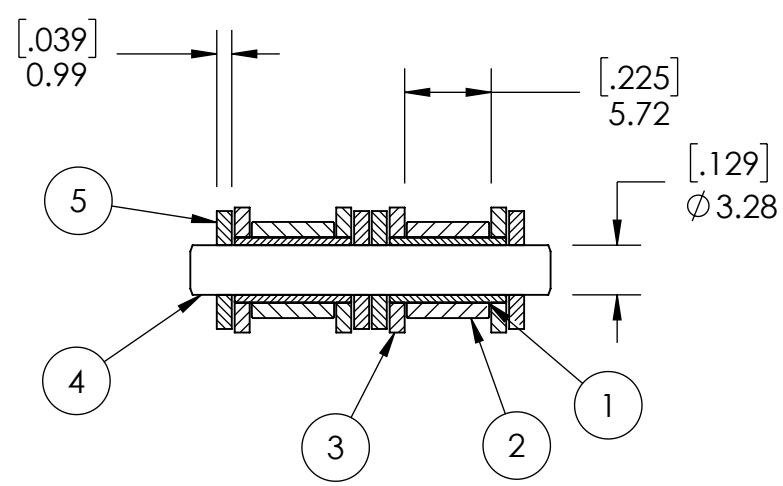
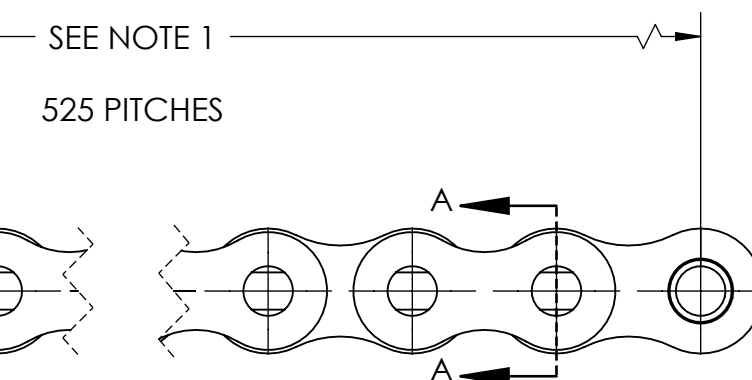
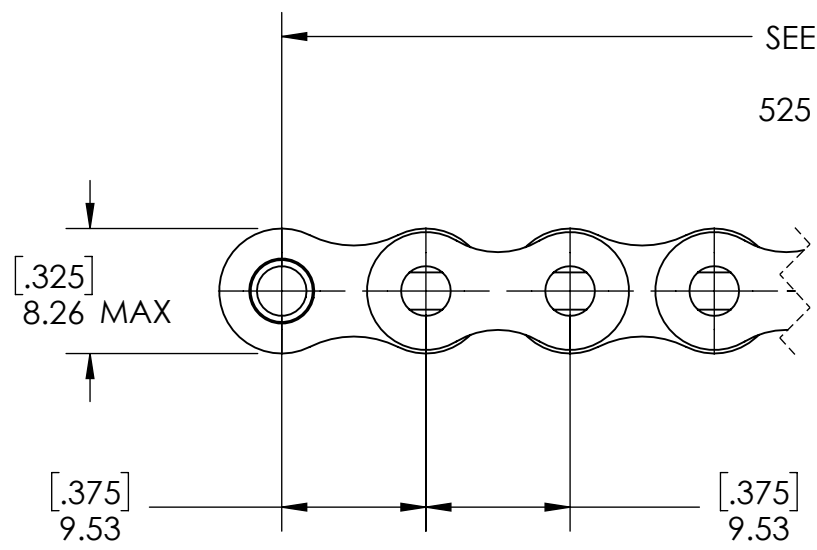
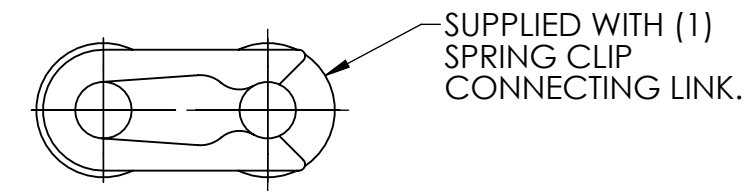
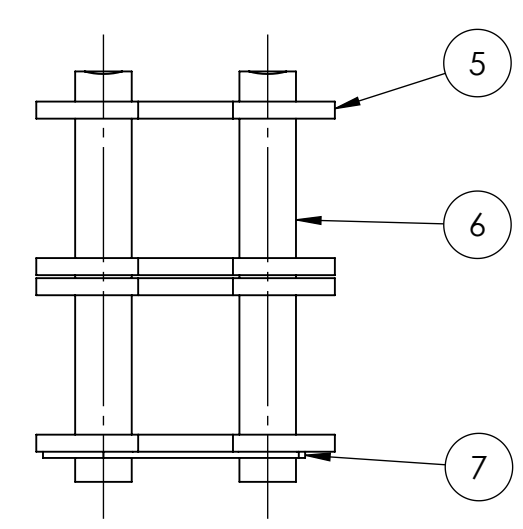
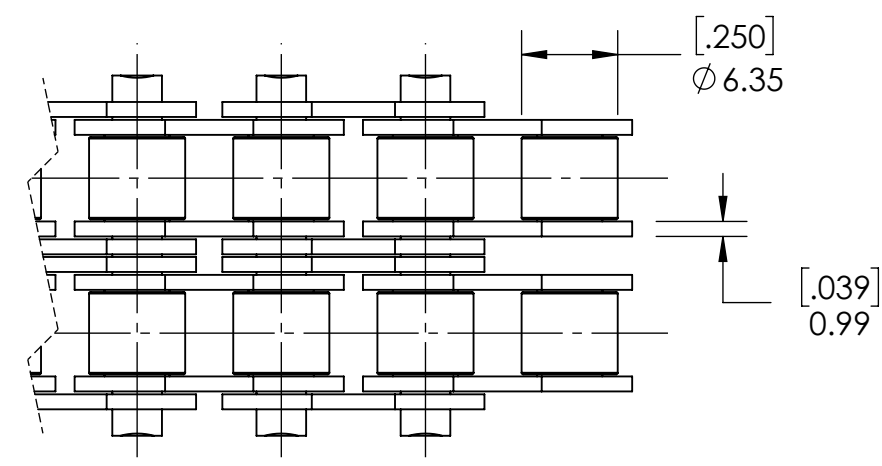
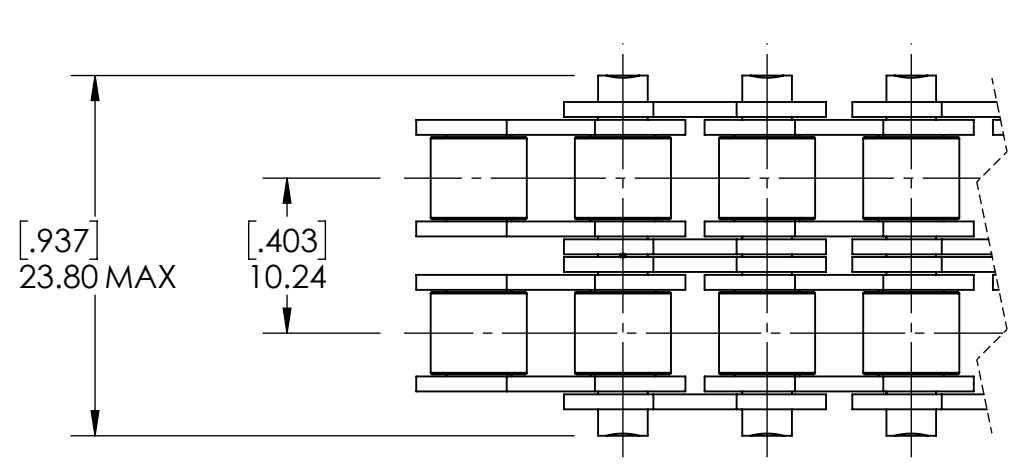

SECTION A-A

NOTES:  
1. SUPPLIED IN LENGTHS OF 5 METERS. ACTUAL LENGTH IS 5011 mm.

CHAINS SPECIFICATIONS	
UNITS	mm (INCH)
CHAIN NO.	06B
PITCH	0.375 IN
ROLLER DIAMETER	6.35 mm
INNER WIDTH	5.72 mm
AVERAGE ULTIMATE TENSILE STRENGTH	3147.33 LBS
CONNECTING LINK TYPE	SPRING CLIP
PIN CONSTRUCTION	SOLID
PIN RETENTION	RIVETED
INDUSTRY STANDARD	ISO 606

**SOLVE** INDUSTRIAL MOTION GROUP  
**PTI**  
 DWG. NO.

WEIGHT	9.62 LBS
MATERIAL	SEE BOM
COATING	ANTI-RUST OIL
DRAWN	SEC 07/11/2025
CHECKED	EG 07/11/2025
APPROVED	

ITEM NO.	PART NUMBER	MATERIAL	COATING
7	E06BSS SPRING CLIP	STAINLESS STEEL	N/A
6	E06B-2SS CONNECTING LINK PIN	STAINLESS STEEL	N/A
5	E06BSS OUTER PLATE	STAINLESS STEEL	N/A
4	E06B-2SSRIV PIN	STAINLESS STEEL	N/A
3	E06BSS INNER PLATE	STAINLESS STEEL	N/A
2	E06BSS ROLLER	STAINLESS STEEL	N/A
1	E06BSS BUSHING	STAINLESS STEEL	N/A

DATE	BY	REVISION DESCRIPTION	REV
ITEM DESCRIPTION: E06B-2SSRIV			SCALE 1:2
			REV -

9 8 7 6 5 4 3 2 1