

SECTION VIEW A-A

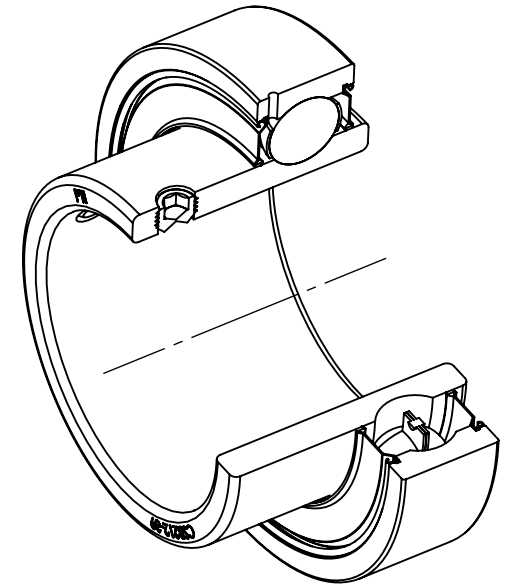

SPECIFICATIONS		WEIGHT		REVISION DESCRIPTION		REV
UNITS:	IN (mm)	2.36 LBS				
LOAD RATINGS	C: 11,800 LBS Co: 8,090 LBS	BEARING STEEL				
SPEED RATING	2800 RPM	N/A				
GREASE TYPE	NLGI #2	DRAWN	SEC	01/16/2025		
GREASE FILL	40%	CHECKED	SEC	01/16/2025		
OPERATING TEMP	10°F - 200°F	APPROVED		DATE		BY
SEAL TYPE	K-TYPE	THIRD ANGLE PROJECTION		ITEM DESCRIPTION:		REV
INTERNAL CLEARANCE	C3	DWG. NO.		CSB212-39		SCALE
TORQUE SETTING ON SET SCREWS		PROPRIETARY AND CONFIDENTIAL				1:10
		THE INFORMATION CONTAINED IN THIS DRAWING IS THE SOLE PROPERTY OF SOLVE IMG. ANY REPRODUCTION IN PART OR AS A WHOLE WITHOUT THE WRITTEN PERMISSION OF SOLVE IMG IS PROHIBITED.				REV
						-