

9 8 7 6 5 4 3 2 1

G F E D C B A

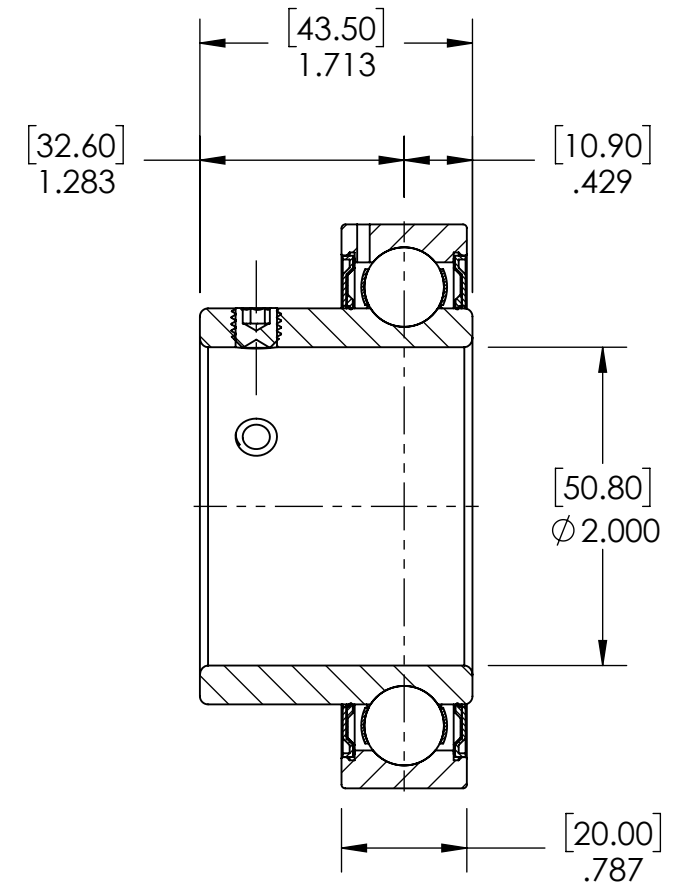

SECTION VIEW A-A

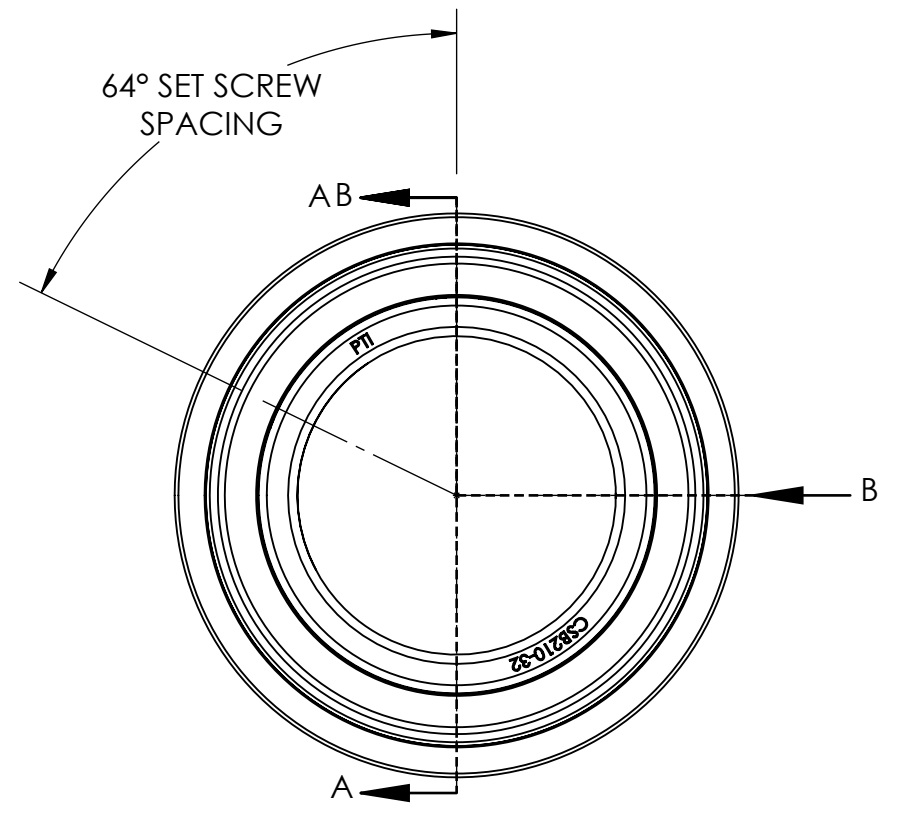
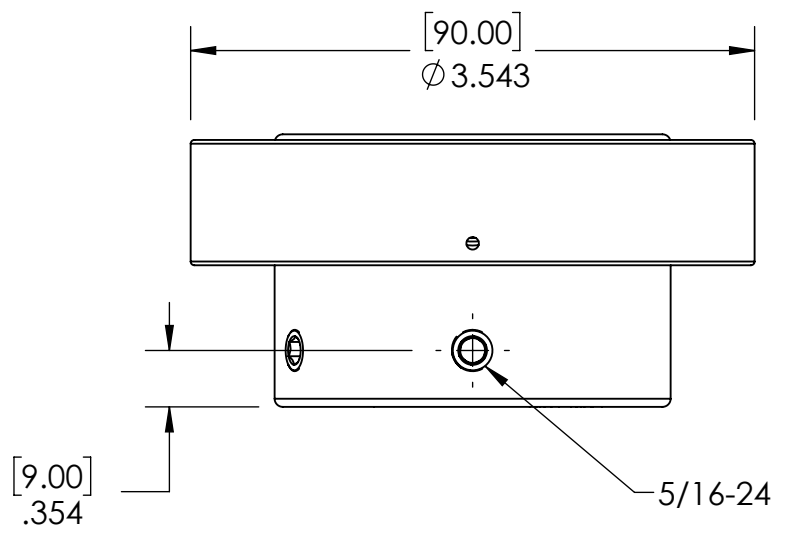
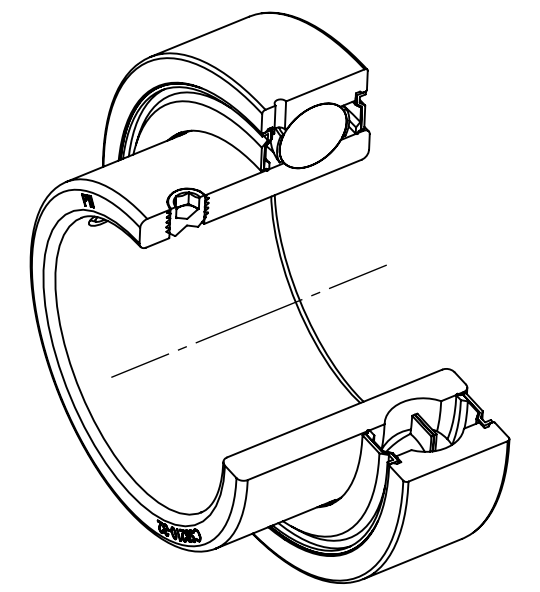

SPECIFICATIONS		WEIGHT		REVISION DESCRIPTION		REV
UNITS:	IN (mm)		1.41 LBS			
LOAD RATINGS	C: 7,900 LBS Co: 5,190 LBS		BEARING STEEL			
SPEED RATING	3400 RPM		COATING	N/A		
GREASE TYPE	NLGI #2		DRAWN	SEC 01/16/2025		
GREASE FILL	40%		CHECKED	SEC 01/16/2025		
OPERATING TEMP	10°F - 200°F		APPROVED		DATE	BY
SEAL TYPE	K-TYPE		THIRD ANGLE PROJECTION		ITEM DESCRIPTION:	
INTERNAL CLEARANCE	C3				CSB210-32	
TORQUE SETTING ON SET SCREWS						



PROPRIETARY AND CONFIDENTIAL  
THE INFORMATION CONTAINED IN THIS DRAWING IS THE SOLE PROPERTY OF SOLVE IMG. ANY REPRODUCTION IN PART OR AS A WHOLE WITHOUT THE WRITTEN PERMISSION OF SOLVE IMG IS PROHIBITED.

9 8 7 6 5 4 3 2 1

A B C D E F G