

SECTION VIEW A-A

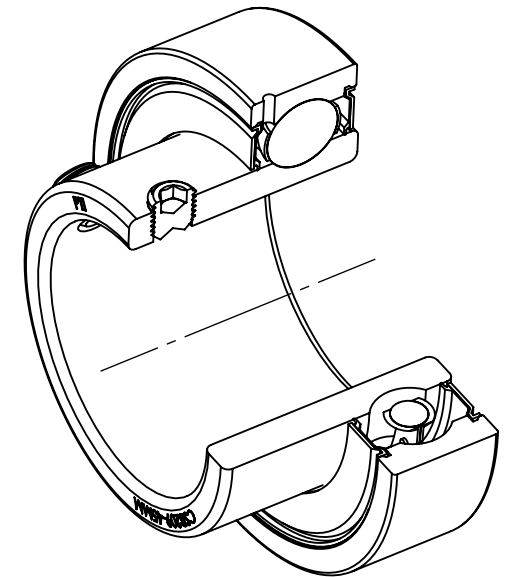

SPECIFICATIONS	
UNITS:	IN (mm)
LOAD RATINGS	C: 7,390 LBS Co: 4,584 LBS
SPEED RATING	3700 RPM
GREASE TYPE	NLGI #2
GREASE FILL	40%
OPERATING TEMP	10°F - 200°F
SEAL TYPE	K-TYPE
INTERNAL CLEARANCE	C3
TORQUE SETTING ON SET SCREWS	



WEIGHT	1.24 LBS
MATERIAL	BEARING STEEL
COATING	N/A
DRAWN	SEC 01/16/2025
CHECKED	SEC 01/16/2025
APPROVED	

THIRD ANGLE PROJECTION

 PROPRIETARY AND CONFIDENTIAL
 THE INFORMATION CONTAINED IN THIS DRAWING IS THE SOLE PROPERTY OF SOLVE IMG. ANY REPRODUCTION IN PART OR AS A WHOLE WITHOUT THE WRITTEN PERMISSION OF SOLVE IMG IS PROHIBITED.

DATE	BY	REVISION DESCRIPTION	REV
ITEM DESCRIPTION:			SCALE
CSB209-45MM			1:12
			REV
			-