

SECTION VIEW A-A

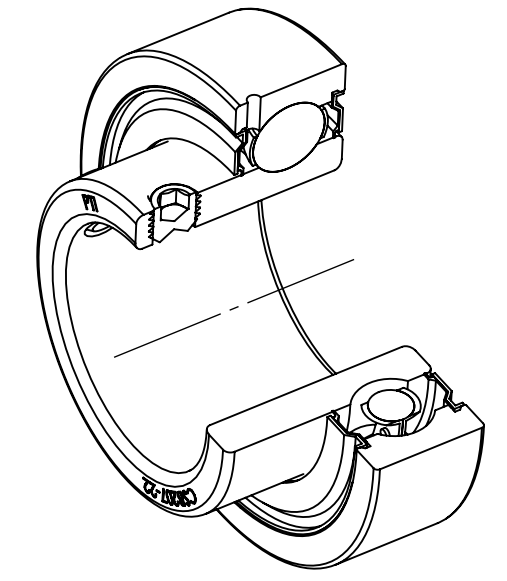

SPECIFICATIONS		WEIGHT		REVISION DESCRIPTION		REV
UNITS:	IN (mm)		0.82 LBS			
LOAD RATINGS	C: 5,780 LBS Co: 3,440 LBS	MATERIAL	BEARING STEEL			
SPEED RATING	4500 RPM	COATING	N/A			
GREASE TYPE	NLGI #2	DRAWN	SEC 01/16/2025			
GREASE FILL	40%	CHECKED	SEC 01/16/2025			
OPERATING TEMP	10°F - 200°F	APPROVED		DATE	BY	
SEAL TYPE	K-TYPE	THIRD ANGLE PROJECTION		ITEM DESCRIPTION:		SCALE
INTERNAL CLEARANCE	C3			CSB207-22		1:15
TORQUE SETTING ON SET SCREWS						REV
						-



DWG. NO. PROPRIETARY AND CONFIDENTIAL
THE INFORMATION CONTAINED IN THIS DRAWING IS THE SOLE PROPERTY OF SOLVE IMG. ANY REPRODUCTION IN PART OR AS A WHOLE WITHOUT THE WRITTEN PERMISSION OF SOLVE IMG IS PROHIBITED.