

9 8 7 6 5 4 3 2 1

G F E D C B A

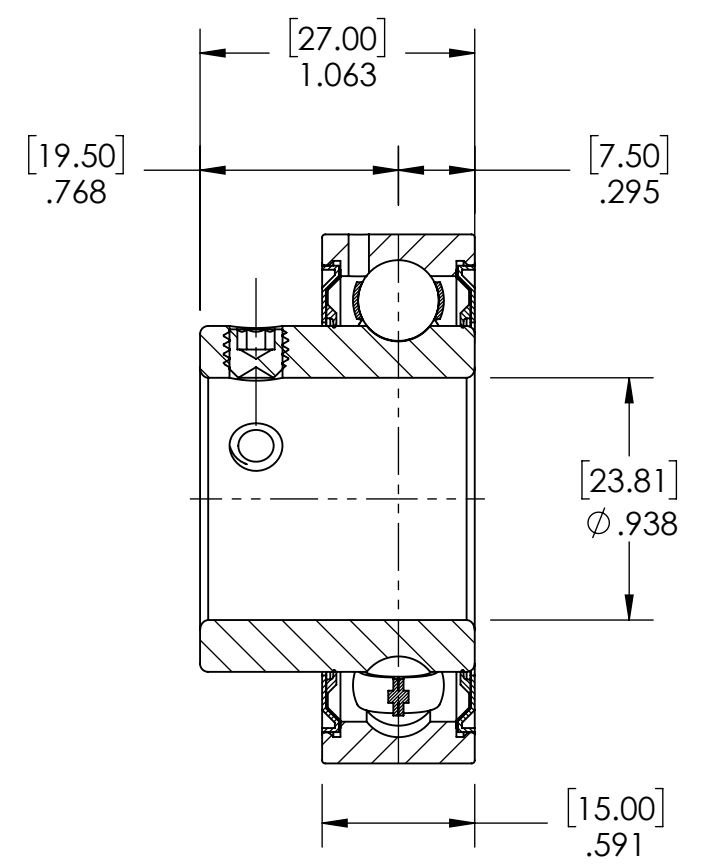
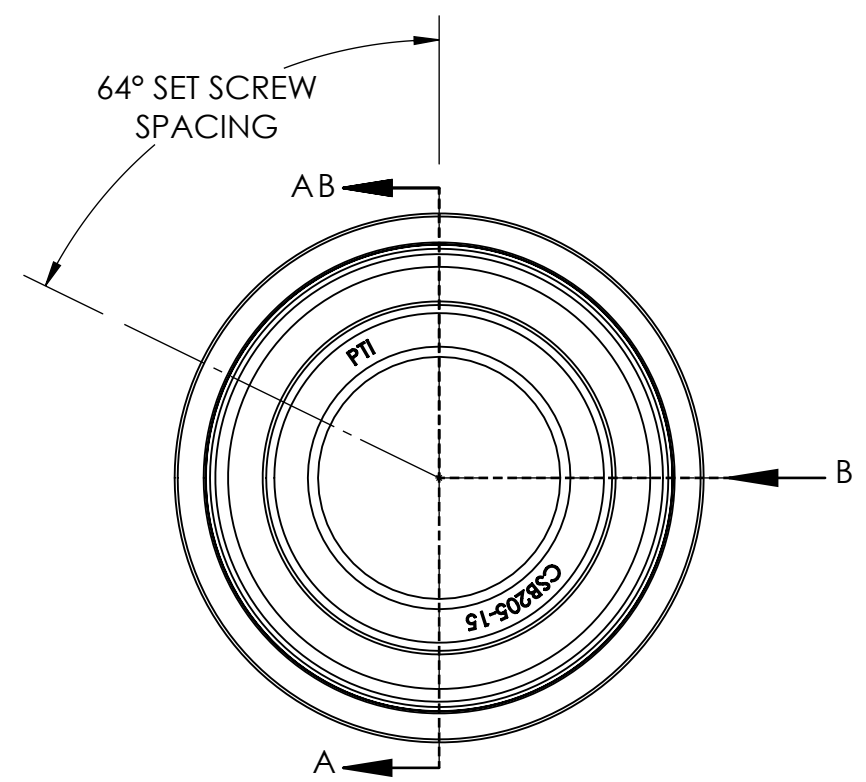
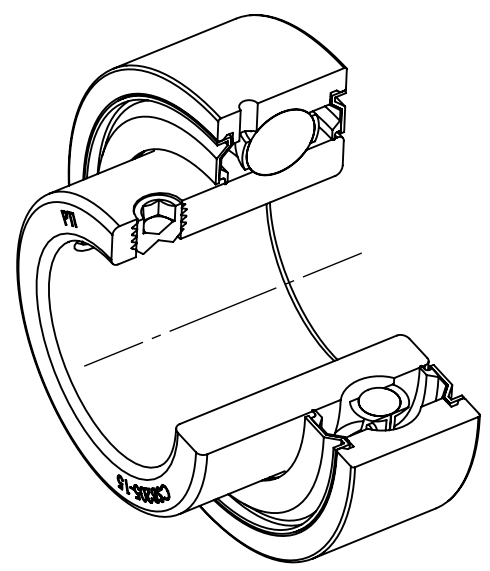
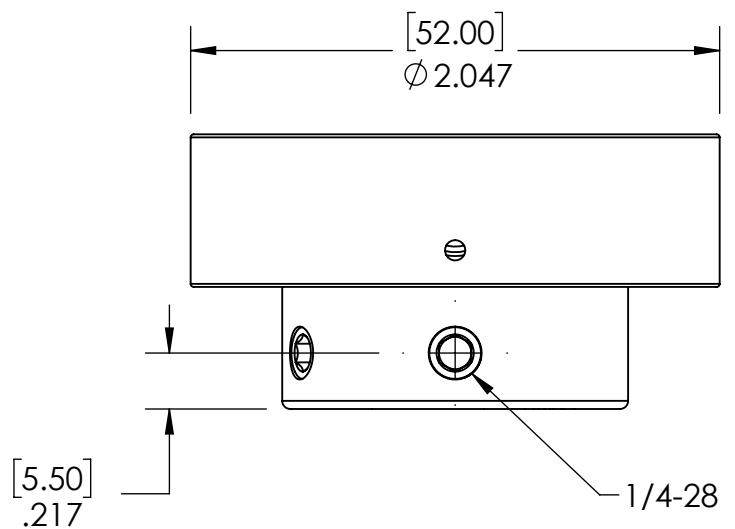

SECTION VIEW A-A

SPECIFICATIONS		WEIGHT		REVISION DESCRIPTION		REV
UNITS:	IN (mm)	0.39 LBS				
LOAD RATINGS	C: 3,140 LBS	MATERIAL	BEARING STEEL			
	Co: 1,750 LBS	COATING	N/A			
SPEED RATING	6250 RPM	DRAWN	SEC 01/16/2025			
GREASE TYPE	NLGI #2	CHECKED	SEC 01/16/2025			
GREASE FILL	40%	APPROVED		DATE	BY	
OPERATING TEMP	10°F - 200°F	THIRD ANGLE PROJECTION		ITEM DESCRIPTION:		SCALE
SEAL TYPE	K-TYPE	DWG. NO.		CSB205-15		1:20
INTERNAL CLEARANCE	C3	PROPRIETARY AND CONFIDENTIAL				REV
TORQUE SETTING ON SET SCREWS		THE INFORMATION CONTAINED IN THIS DRAWING IS THE SOLE PROPERTY OF SOLVE IMG. ANY REPRODUCTION IN PART OR AS A WHOLE WITHOUT THE WRITTEN PERMISSION OF SOLVE IMG IS PROHIBITED.				-

9 8 7 6 5 4 3 2 1

A B C D E F G