

9 8 7 6 5 4 3 2 1

G F E D C B A

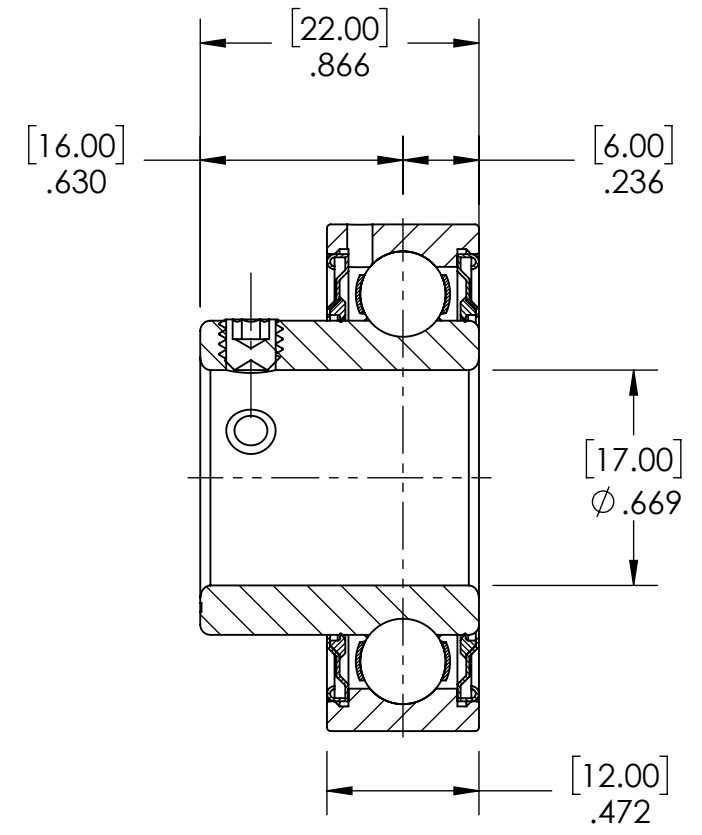
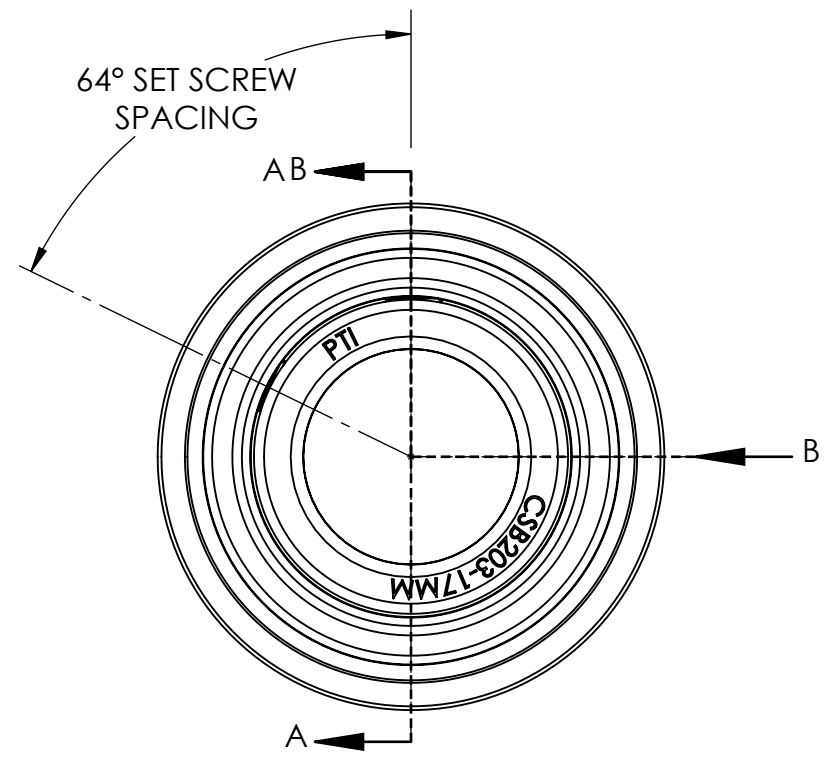
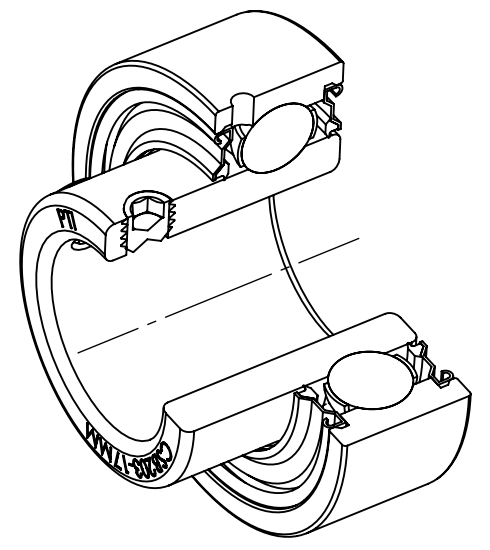
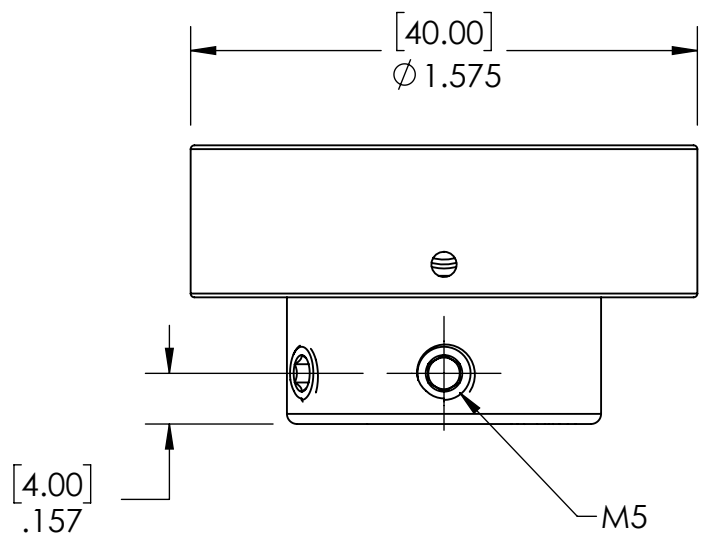

SECTION VIEW A-A

SPECIFICATIONS		WEIGHT		REVISION DESCRIPTION		REV
UNITS:	IN (mm)	0.18 LBS				
LOAD RATINGS	C: 2,140 LBS Co: 1,060 LBS	MATERIAL	BEARING STEEL			
SPEED RATING	8800 RPM	COATING	N/A			
GREASE TYPE	NLGI #2	DRAWN	SEC 01/16/2025			
GREASE FILL	40%	CHECKED	SEC 01/16/2025			
OPERATING TEMP	10°F - 200°F	APPROVED		DATE	BY	
SEAL TYPE	K-TYPE	THIRD ANGLE PROJECTION		ITEM DESCRIPTION:		SCALE
INTERNAL CLEARANCE	C3	PROPRIETARY AND CONFIDENTIAL		CSB203-17MM		1:25
TORQUE SETTING ON SET SCREWS		THE INFORMATION CONTAINED IN THIS DRAWING IS THE SOLE PROPERTY OF SOLVE IMG. ANY REPRODUCTION IN PART OR AS A WHOLE WITHOUT THE WRITTEN PERMISSION OF SOLVE IMG IS PROHIBITED.				REV
		DWG. NO.				-

9 8 7 6 5 4 3 2 1

A B C D E F G