

SECTION VIEW A-A

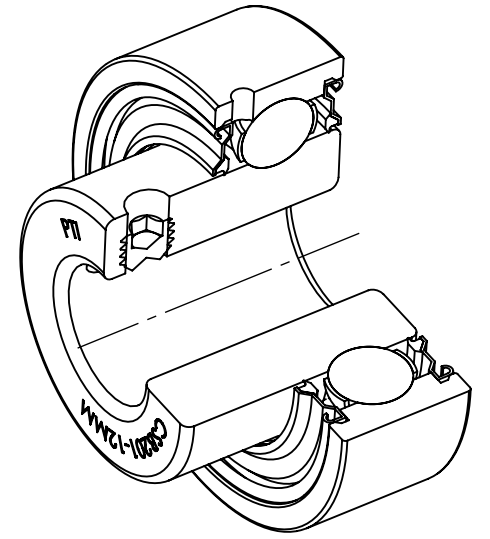

SPECIFICATIONS		WEIGHT		REVISION	
UNITS:	IN (mm)		0.22 LBS		
LOAD RATINGS	C: 2.140 LBS Co: 1.060 LBS		BEARING STEEL		
SPEED RATING	8800 RPM		COATING	N/A	
GREASE TYPE	NLGI #2		DRAWN	SEC 01/16/2025	
GREASE FILL	40%		CHECKED	SEC 01/16/2025	
OPERATING TEMP	10°F - 200°F		APPROVED		
SEAL TYPE	K-TYPE		THIRD ANGLE PROJECTION		
INTERNAL CLEARANCE	C3				
TORQUE SETTING ON SET SCREWS					
				DATE	BY
DWG. NO.		PROPRIETARY AND CONFIDENTIAL <small>THE INFORMATION CONTAINED IN THIS DRAWING IS THE SOLE PROPERTY OF SOLVE IMG. ANY REPRODUCTION IN PART OR AS A WHOLE WITHOUT THE WRITTEN PERMISSION OF SOLVE IMG IS PROHIBITED.</small>		REVISION DESCRIPTION	
ITEM DESCRIPTION:				REV	SCALE
CSB201-12MM				1:25	
				REV	
				-	