

9 8 7 6 5 4 3 2 1

G
F
E
D
C
B
A

G
F
E
D
C
B
A

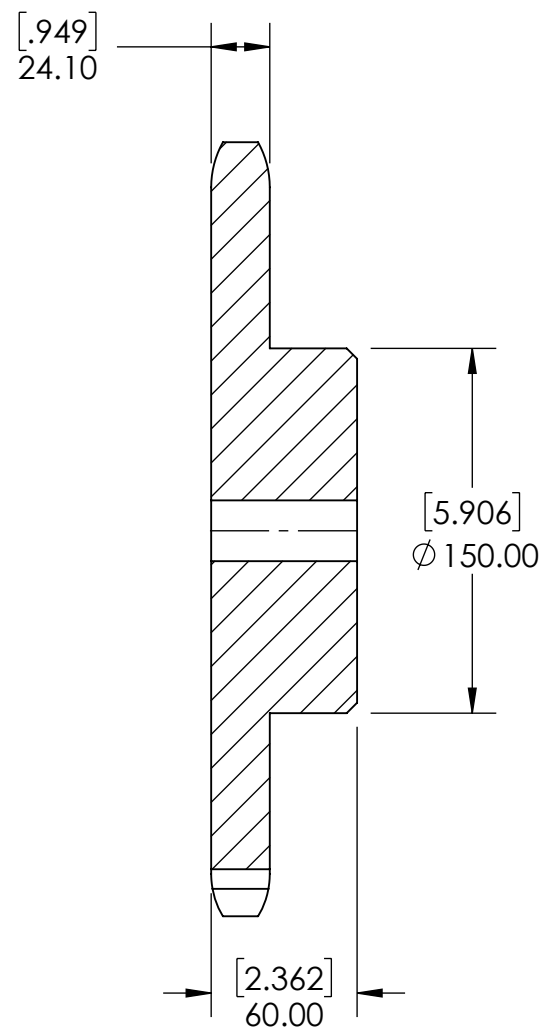
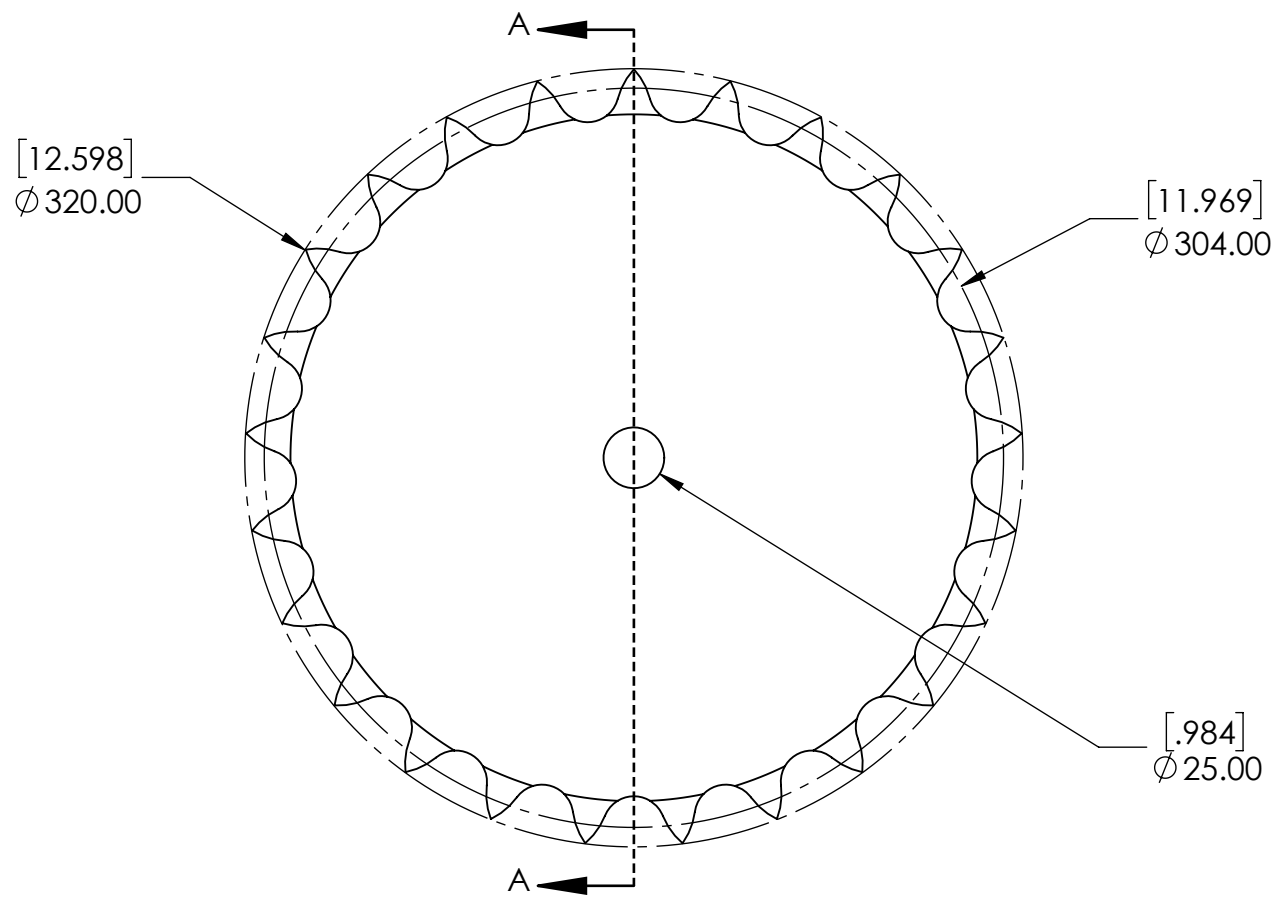

SECTION A-A

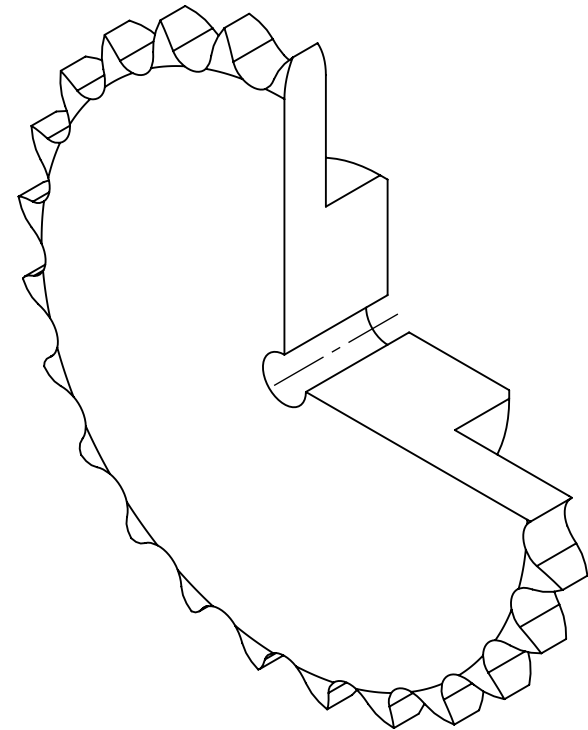

SPROCKETS SPECIFICATIONS		WEIGHT		DATE		BY		REVISION DESCRIPTION		REV
UNITS	mm (INCH)	38.30 LBS								
CHAIN SIZE	24B	MATERIAL	STEEL							
PITCH	38.10 mm	COATING	BLACK OXIDE							
INNER WIDTH	25.40 mm	DRAWN	SEC	07/21/2025						
ROLLER DIA.	25.40 mm	CHECKED								
TOOTH WIDTH	24.10 mm	APPROVED								
NUMBER OF TEETH	25					ITEM DESCRIPTION:		24B-25B		SCALE
HUB STYLE	B									DWG. NO.
BORE TYPE	PLAIN BORE									REV
BUSHING NUMBER	N/A									-

9 8 7 6 5 4 3 2 1