

9 8 7 6 5 4 3 2 1

G
F
E
D
C
B
A

G
F
E
D
C
B
A

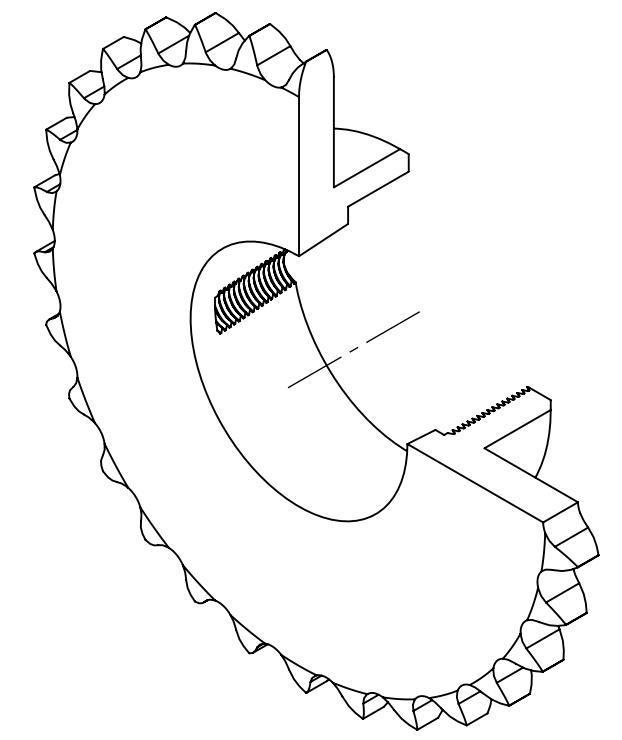
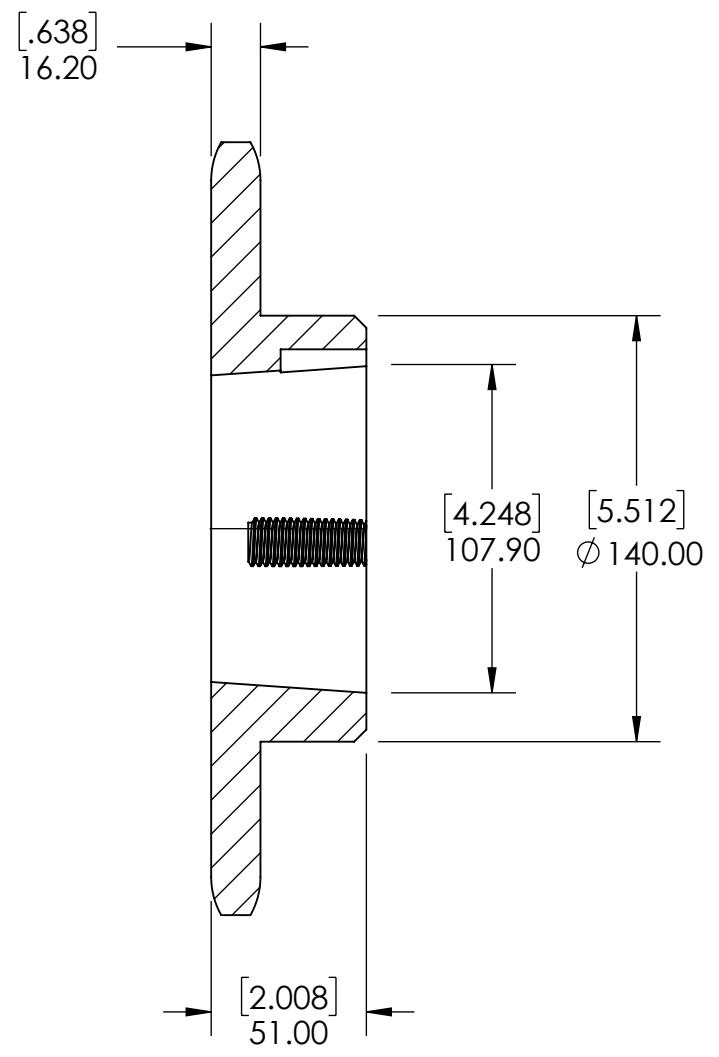
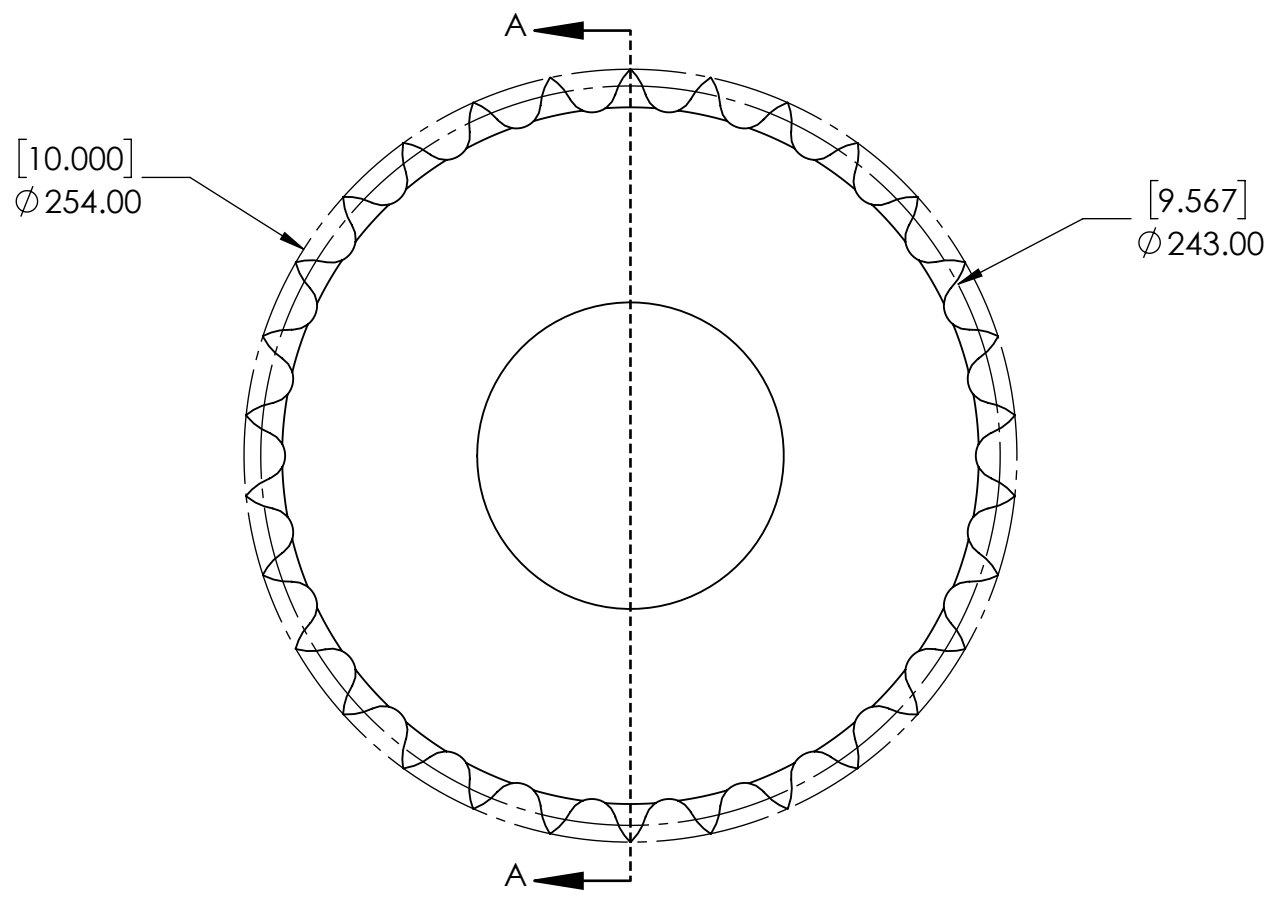

SECTION A-A

NOTES:
1. HARDENED TEETH.

SPROCKETS SPECIFICATIONS		WEIGHT		13.84 LBS	
UNITS	mm (INCH)	MATERIAL	STEEL		
CHAIN SIZE	16B	COATING	BLACK OXIDE		
PITCH	25.40 mm	DRAWN	SEC	07/21/2025	
INNER WIDTH	17.02 mm	CHECKED	SEC	07/28/2025	
ROLLER DIA.	15.88 mm	APPROVED	DATE BY REVISION DESCRIPTION		
TOOTH WIDTH	16.20 mm		ITEM DESCRIPTION:		
NUMBER OF TEETH	30		16B-30HTL-3020		
HUB STYLE	B	DWG. NO.		REV	
BORE TYPE	FOR TAPER BUSHING			SCALE	
BUSHING NUMBER	3020	<small>PROPRIETARY AND CONFIDENTIAL THE INFORMATION CONTAINED IN THIS DRAWING IS THE SOLE PROPERTY OF SOLVE IMG. ANY REPRODUCTION IN PART OR AS A WHOLE WITHOUT THE WRITTEN PERMISSION OF SOLVE IMG IS PROHIBITED.</small>		1:1	
				REV -	

9 8 7 6 5 4 3 2 1