

9 8 7 6 5 4 3 2 1

G F E D C B A

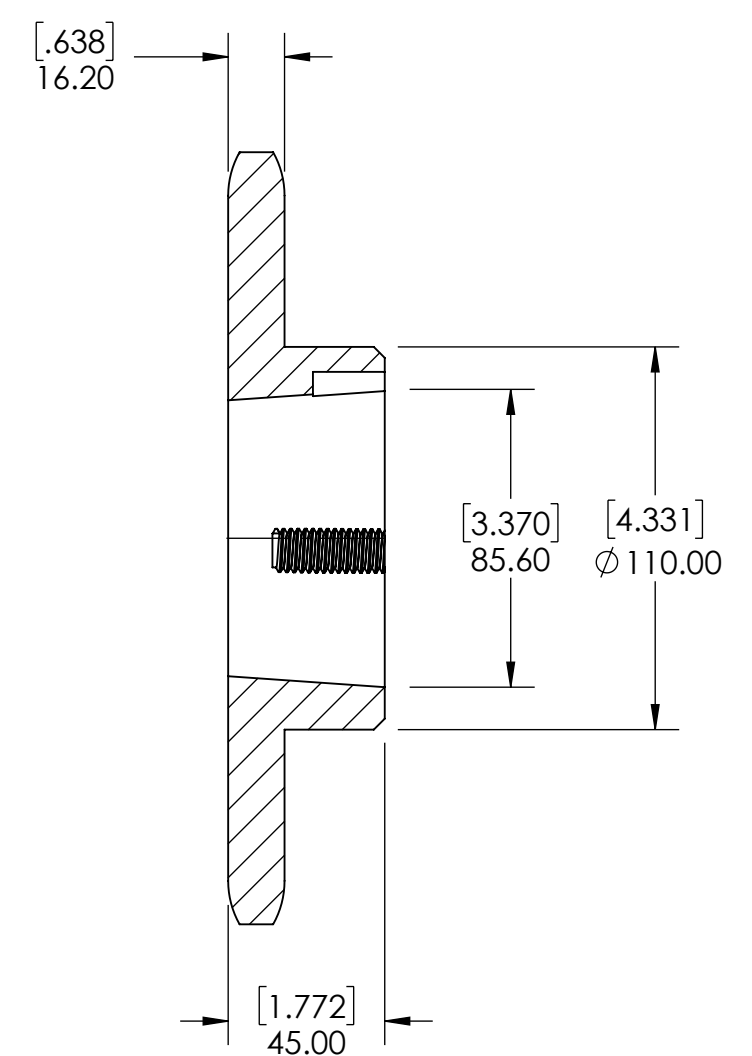

SECTION A-A

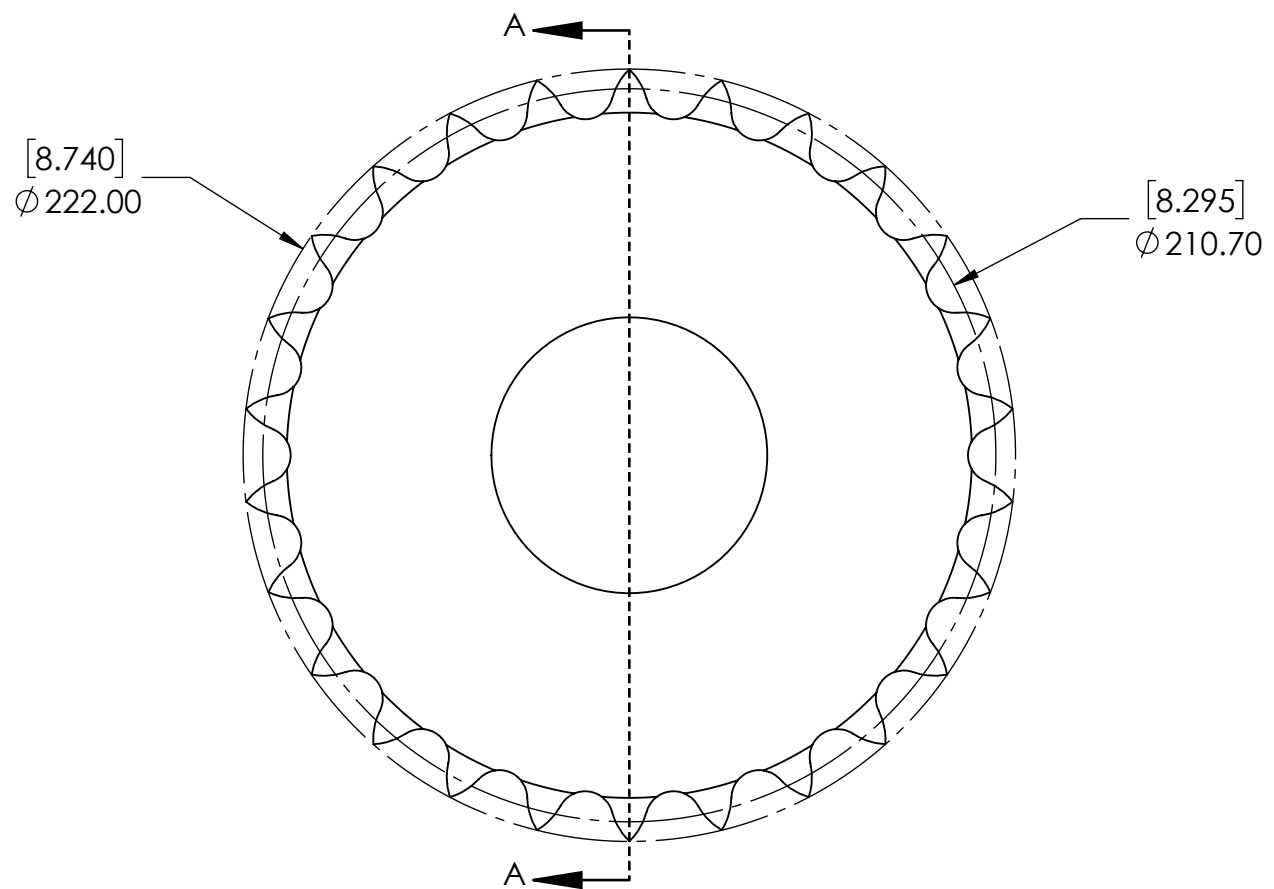
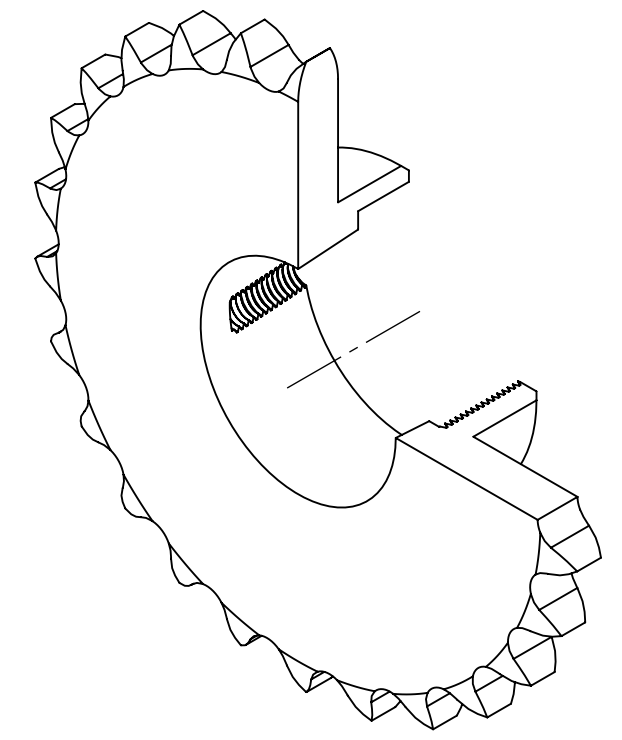

A B C D E F G

9 8 7 6 5 4 3 2 1

SPROCKETS SPECIFICATIONS		WEIGHT		DATE		BY		REVISION DESCRIPTION		REV
UNITS	mm (INCH)	9.64 LBS								SCALE
CHAIN SIZE	16B	MATERIAL	STEEL							1:1
PITCH	25.40 mm	COATING	BLACK OXIDE	DRAWN	SEC	07/21/2025				REV
INNER WIDTH	17.02 mm	CHECKED	SEC	07/28/2025						-
ROLLER DIA.	15.88 mm	APPROVED								
TOOTH WIDTH	16.20 mm	THIRD ANGLE PROJECTION								
NUMBER OF TEETH	26	PTI								
HUB STYLE	B	DWG. NO.								
BORE TYPE	FOR TAPER BUSHING	PROPRIETARY AND CONFIDENTIAL								
BUSHING NUMBER	2517	THE INFORMATION CONTAINED IN THIS DRAWING IS THE SOLE PROPERTY OF SOLVE IMG. ANY REPRODUCTION IN PART OR AS A WHOLE WITHOUT THE WRITTEN PERMISSION OF SOLVE IMG IS PROHIBITED.								
				ITEM DESCRIPTION:		16B-26TL-2517				