

9 8 7 6 5 4 3 2 1

G
F
E
D
C
B
A

G
F
E
D
C
B
A

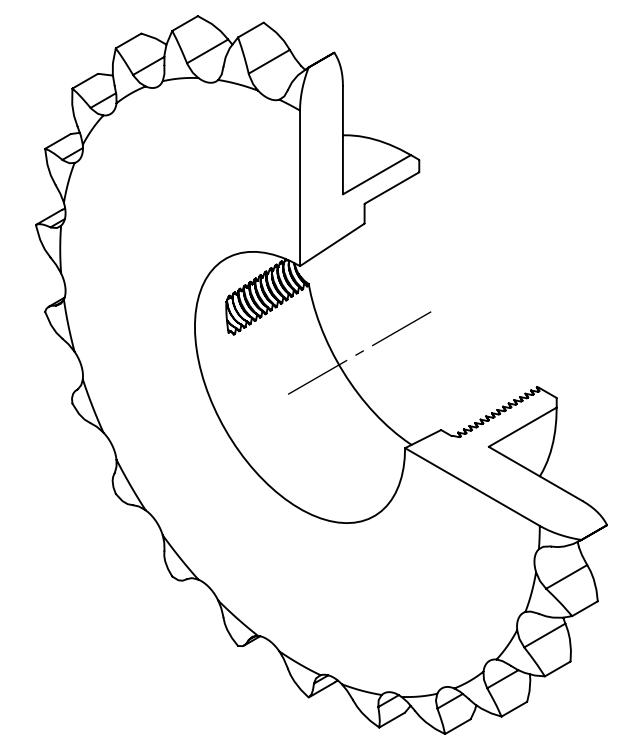
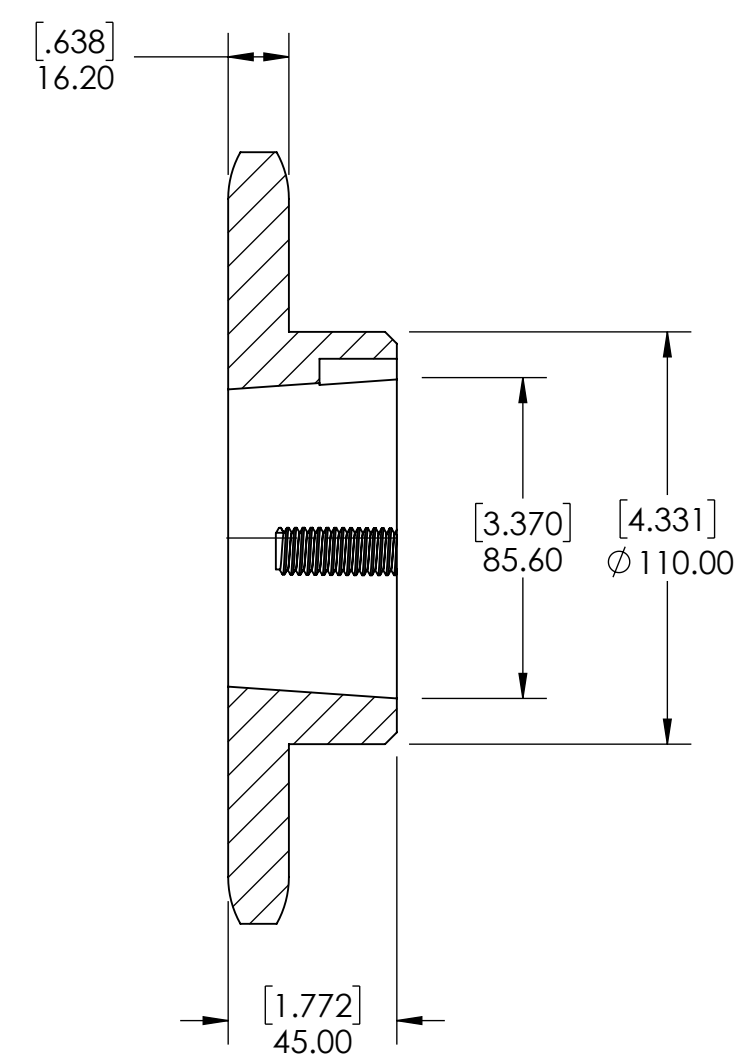
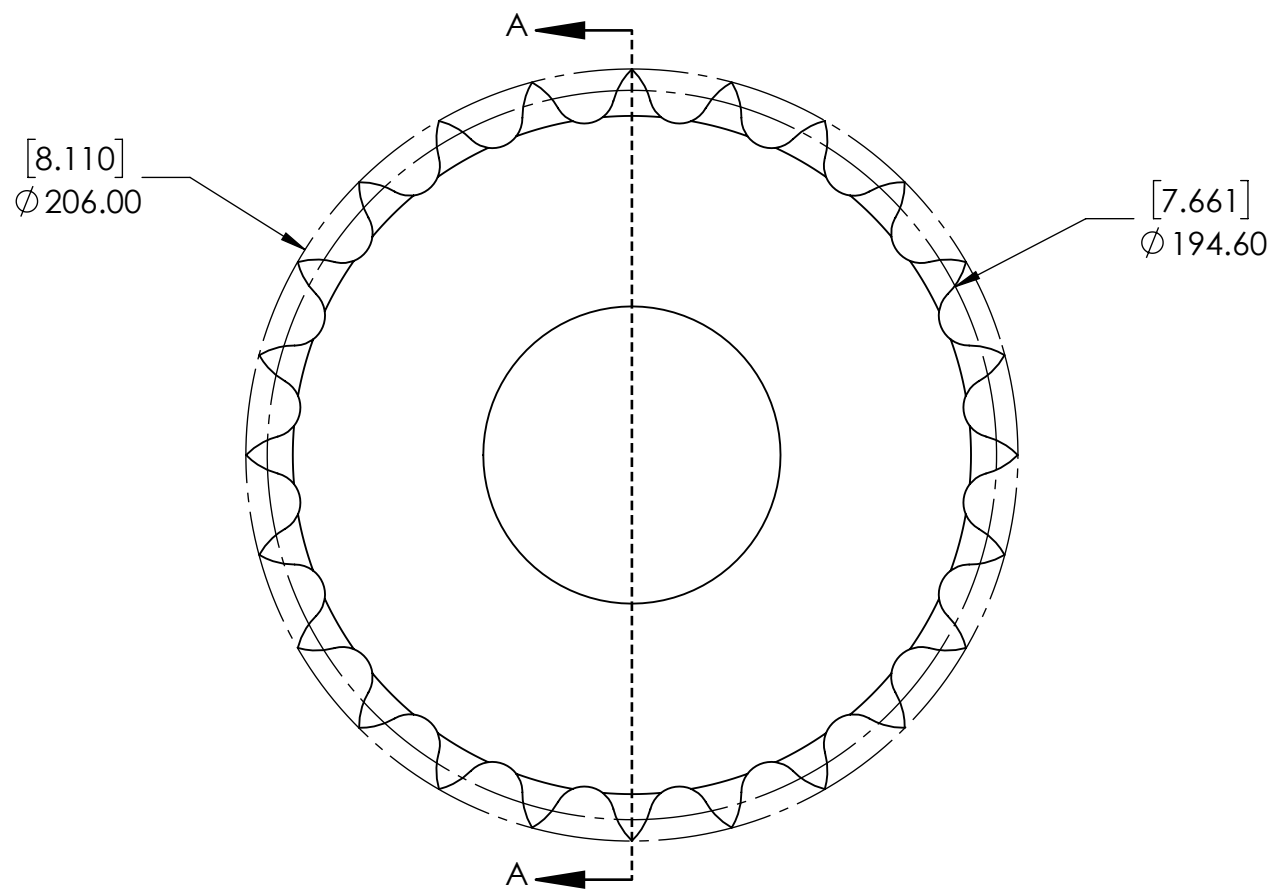

SECTION A-A

SPROCKETS SPECIFICATIONS		WEIGHT		DATE		BY		REVISION DESCRIPTION		REV
UNITS	mm (INCH)	8.25 LBS								
CHAIN SIZE	16B	STEEL								
PITCH	25.40 mm	BLACK OXIDE		DRAWN SEC 07/21/2025						
INNER WIDTH	17.02 mm			CHECKED SEC 07/28/2025						
ROLLER DIA.	15.88 mm			APPROVED						
TOOTH WIDTH	16.20 mm									
NUMBER OF TEETH	24									
HUB STYLE	B			DWG. NO.						
BORE TYPE	FOR TAPER BUSHING									
BUSHING NUMBER	2517					PROPRIETARY AND CONFIDENTIAL THE INFORMATION CONTAINED IN THIS DRAWING IS THE SOLE PROPERTY OF SOLVE IMG. ANY REPRODUCTION IN PART OR AS A WHOLE WITHOUT THE WRITTEN PERMISSION OF SOLVE IMG IS PROHIBITED.				
						ITEM DESCRIPTION:		16B-24TL-2517		SCALE
										1:1
										REV
										-

9 8 7 6 5 4 3 2 1