

9 8 7 6 5 4 3 2 1

G F E D C B A

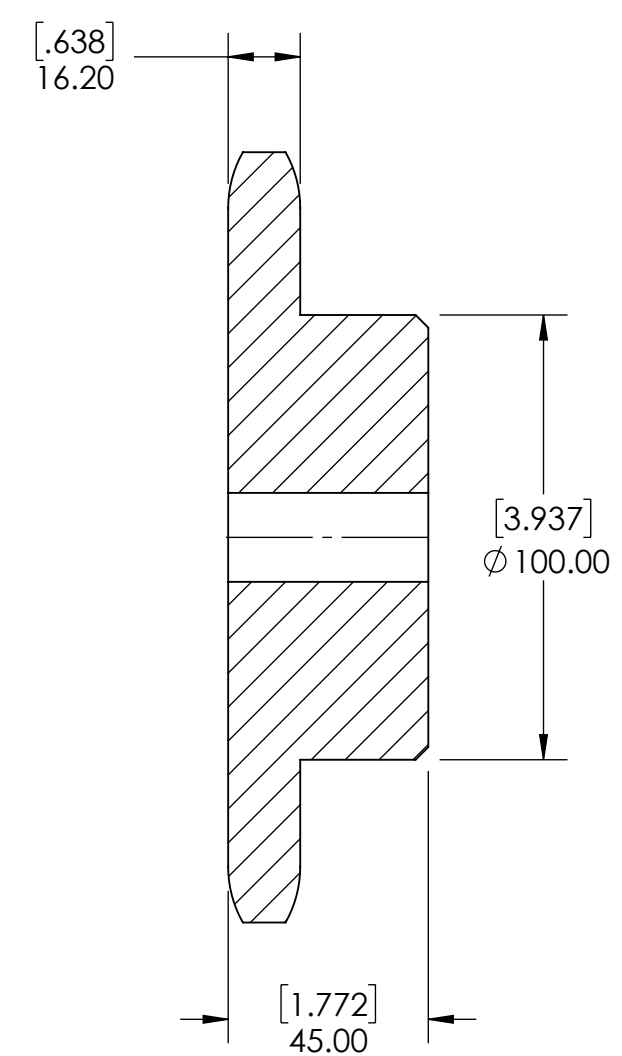

SECTION A-A

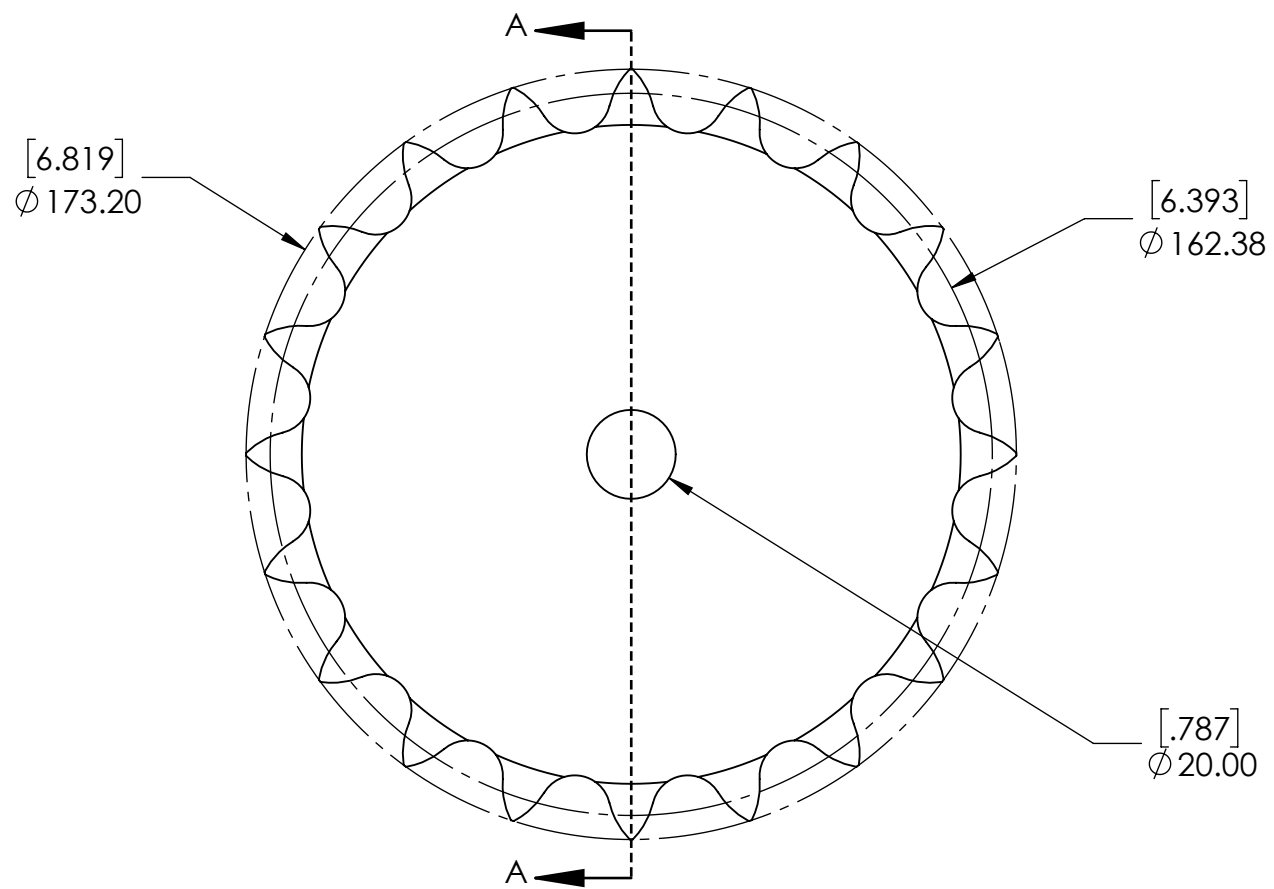
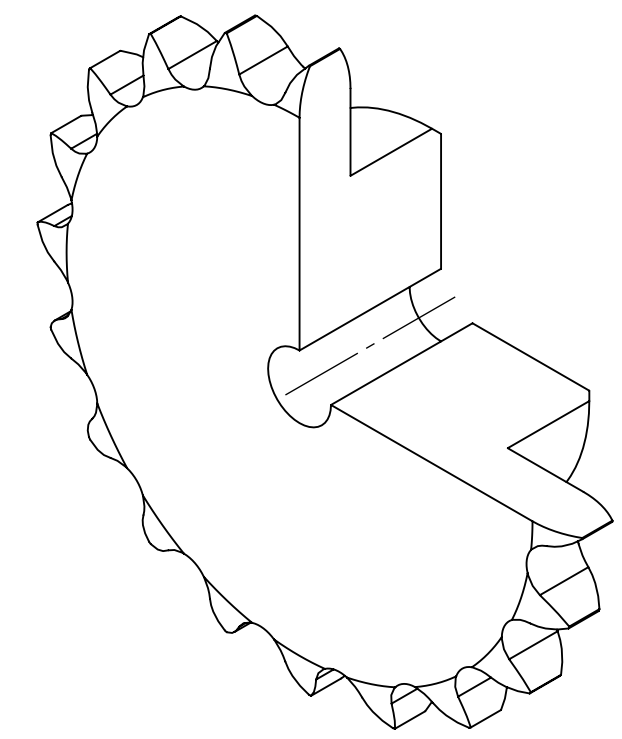

A B C D E F G

9 8 7 6 5 4 3 2 1

SPROCKETS SPECIFICATIONS		WEIGHT		DATE		BY		REVISION DESCRIPTION		REV
UNITS	mm (INCH)	8.99 LBS								
CHAIN SIZE	16B	STEEL								
PITCH	25.40 mm	BLACK OXIDE		07/21/2025						
INNER WIDTH	17.02 mm	DRAWN		SEC						
ROLLER DIA.	15.88 mm	CHECKED		PT		07/29/2025				
TOOTH WIDTH	16.20 mm	APPROVED								
NUMBER OF TEETH	20					ITEM DESCRIPTION:		16B-20B		SCALE
HUB STYLE	B									
BORE TYPE	PLAIN BORE									
BUSHING NUMBER	N/A									
		DWG. NO.		PROPRIETARY AND CONFIDENTIAL						
				THE INFORMATION CONTAINED IN THIS DRAWING IS THE SOLE PROPERTY OF SOLVE IMG. ANY REPRODUCTION IN PART OR AS A WHOLE WITHOUT THE WRITTEN PERMISSION OF SOLVE IMG IS PROHIBITED.						