

9 8 7 6 5 4 3 2 1

G G

F F

E E

D D

C C

B B

A A

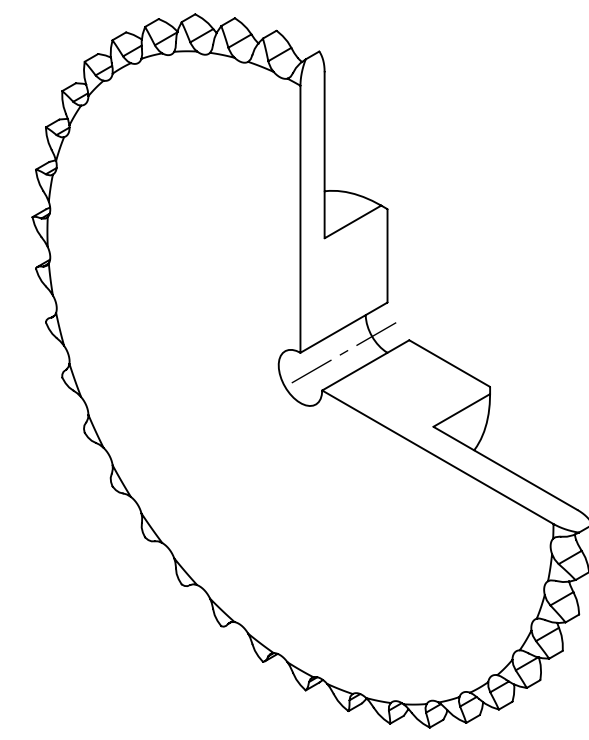
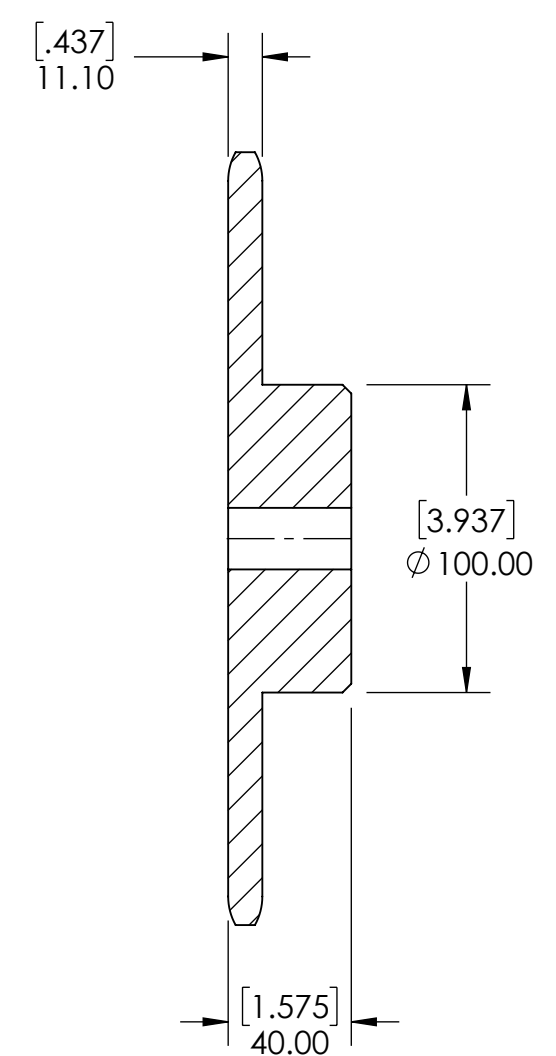
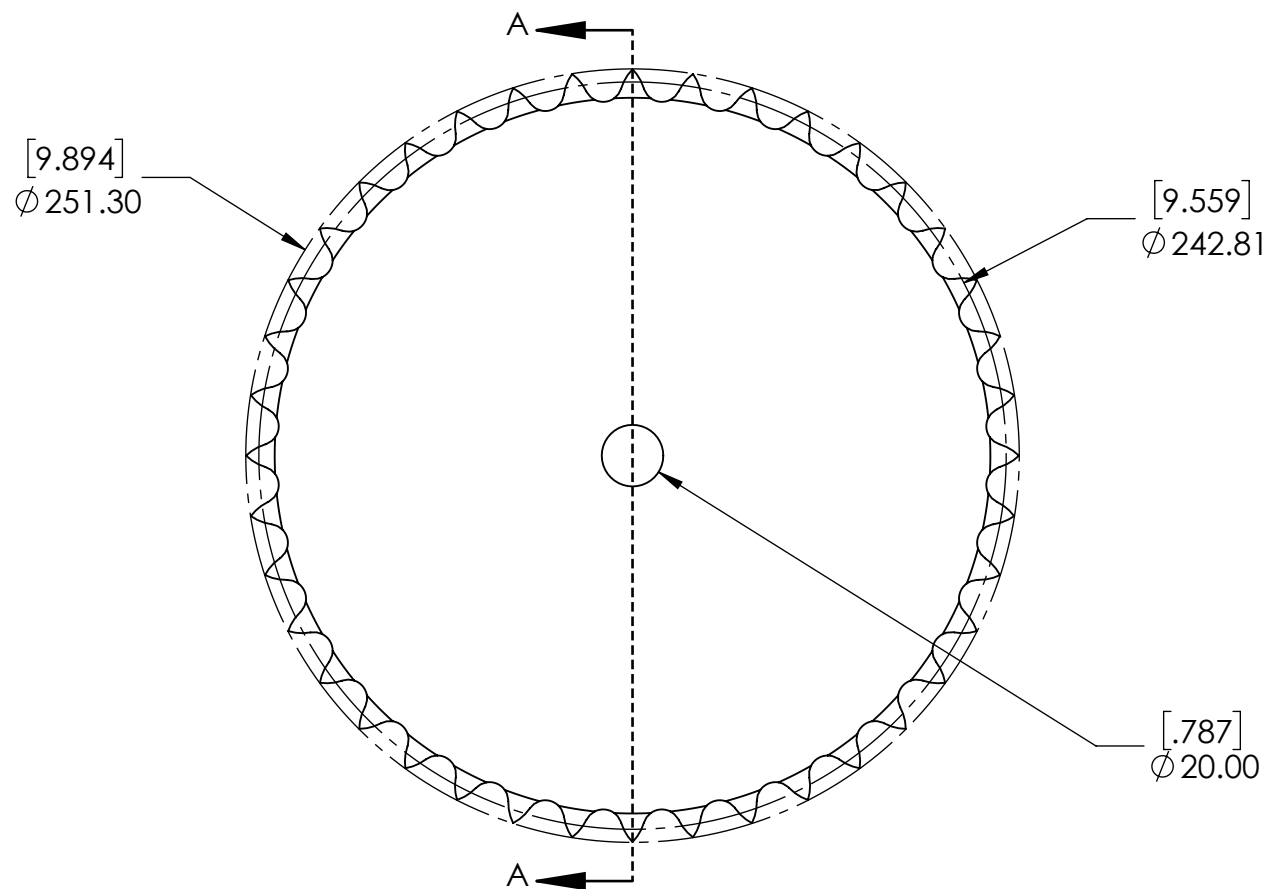

SECTION A-A

SPROCKETS SPECIFICATIONS		WEIGHT		DATE		BY		REVISION DESCRIPTION		REV
UNITS	mm (INCH)	12.20 LBS								
CHAIN SIZE	12B	STEEL								
PITCH	19.05 mm	BLACK OXIDE		07/21/2025						
INNER WIDTH	11.68 mm	DRAWN		DH		08/14/2025				
ROLLER DIA.	12.07 mm	CHECKED		DH		08/14/2025				
TOOTH WIDTH	11.10 mm	APPROVED								
NUMBER OF TEETH	40	THIRD ANGLE PROJECTION								
HUB STYLE	B	DATE								
BORE TYPE	PLAIN BORE	BY								
BUSHING NUMBER	N/A	ITEM DESCRIPTION:								
		DWG. NO.								
		12B-40B								
		SCALE								
		1:1								
		REV								
		-								



PROPRIETARY AND CONFIDENTIAL
THE INFORMATION CONTAINED IN THIS DRAWING IS THE SOLE PROPERTY OF SOLVE IMG. ANY REPRODUCTION IN PART OR AS A WHOLE WITHOUT THE WRITTEN PERMISSION OF SOLVE IMG IS PROHIBITED.

9 8 7 6 5 4 3 2 1