

9 8 7 6 5 4 3 2 1

G
F
E
D
C
B
A

G
F
E
D
C
B
A

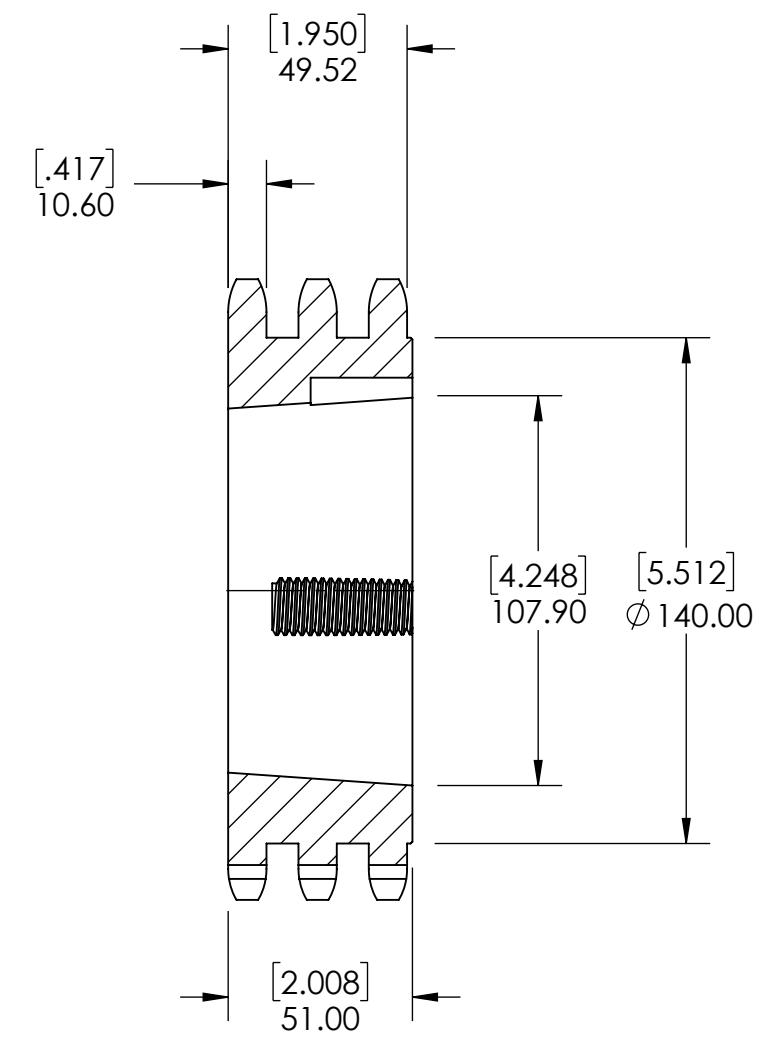
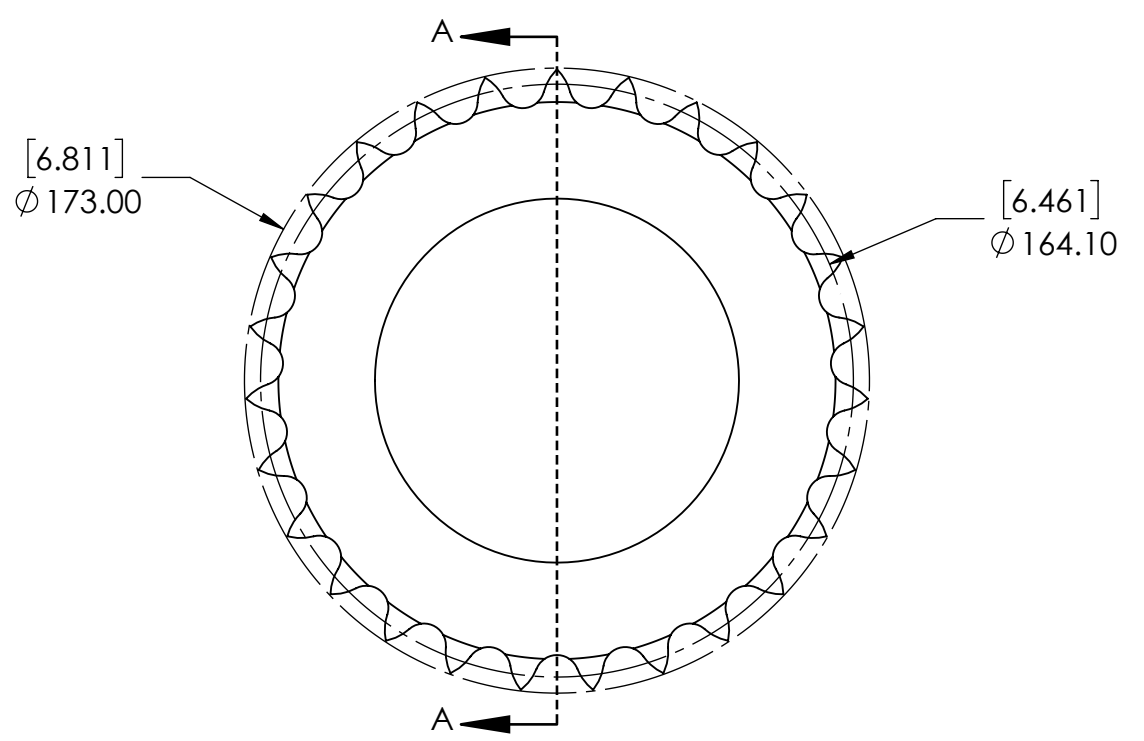

SECTION A-A

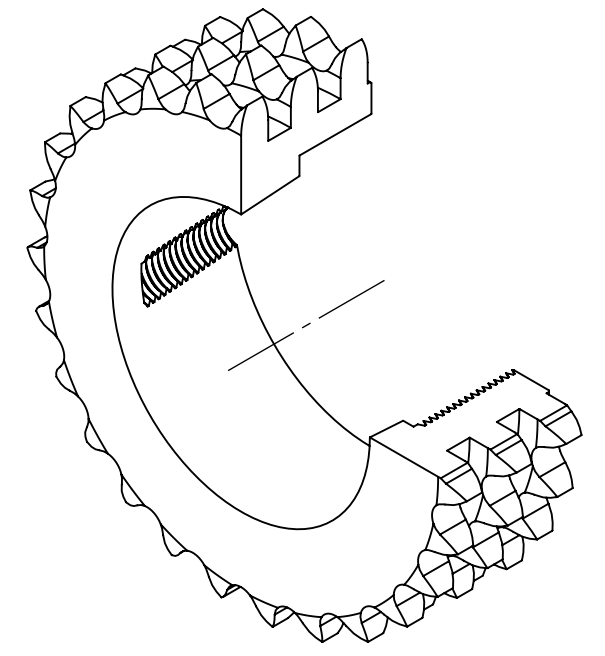

SPROCKETS SPECIFICATIONS		WEIGHT		8.36 LBS	
UNITS	mm (INCH)	MATERIAL	STEEL		
CHAIN SIZE	12B	COATING	BLACK OXIDE		
PITCH	19.05 mm	DRAWN	SEC	07/31/2025	
INNER WIDTH	11.68 mm	CHECKED	SEC	07/31/2025	
ROLLER DIA.	12.07 mm	APPROVED	DATE BY REVISION DESCRIPTION		
TOOTH WIDTH	10.60 mm		ITEM DESCRIPTION:		
NUMBER OF TEETH	27		12B-3-27TL-3020		
HUB STYLE	B	DWG. NO.		SCALE	
BORE TYPE	FOR TAPER BUSHING	<small>PROPRIETARY AND CONFIDENTIAL</small> <small>THE INFORMATION CONTAINED IN THIS DRAWING IS THE SOLE PROPERTY OF SOLVE IMG. ANY REPRODUCTION IN PART OR AS A WHOLE WITHOUT THE WRITTEN PERMISSION OF SOLVE IMG IS PROHIBITED.</small>		1:1	
BUSHING NUMBER	3020			REV	
				-	

9 8 7 6 5 4 3 2 1