

9 8 7 6 5 4 3 2 1

G
F
E
D
C
B
A

G
F
E
D
C
B
A

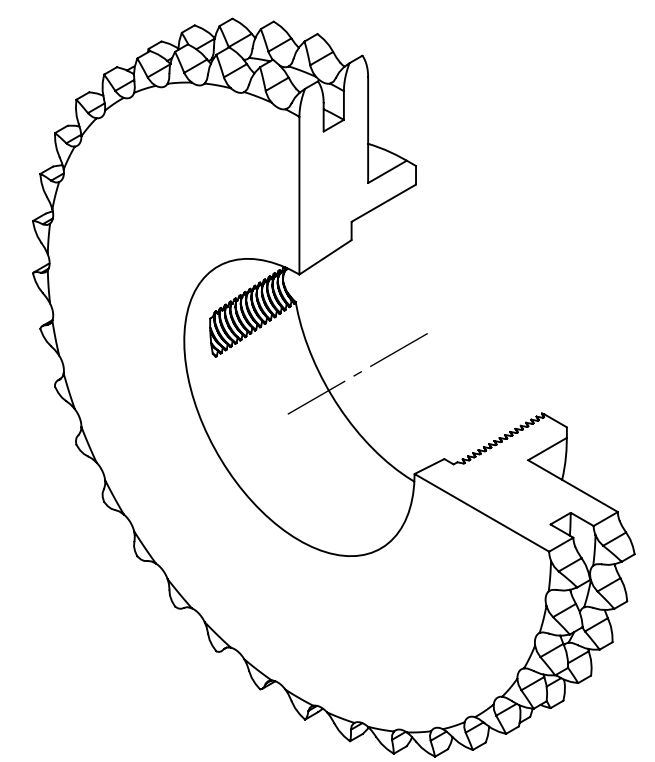
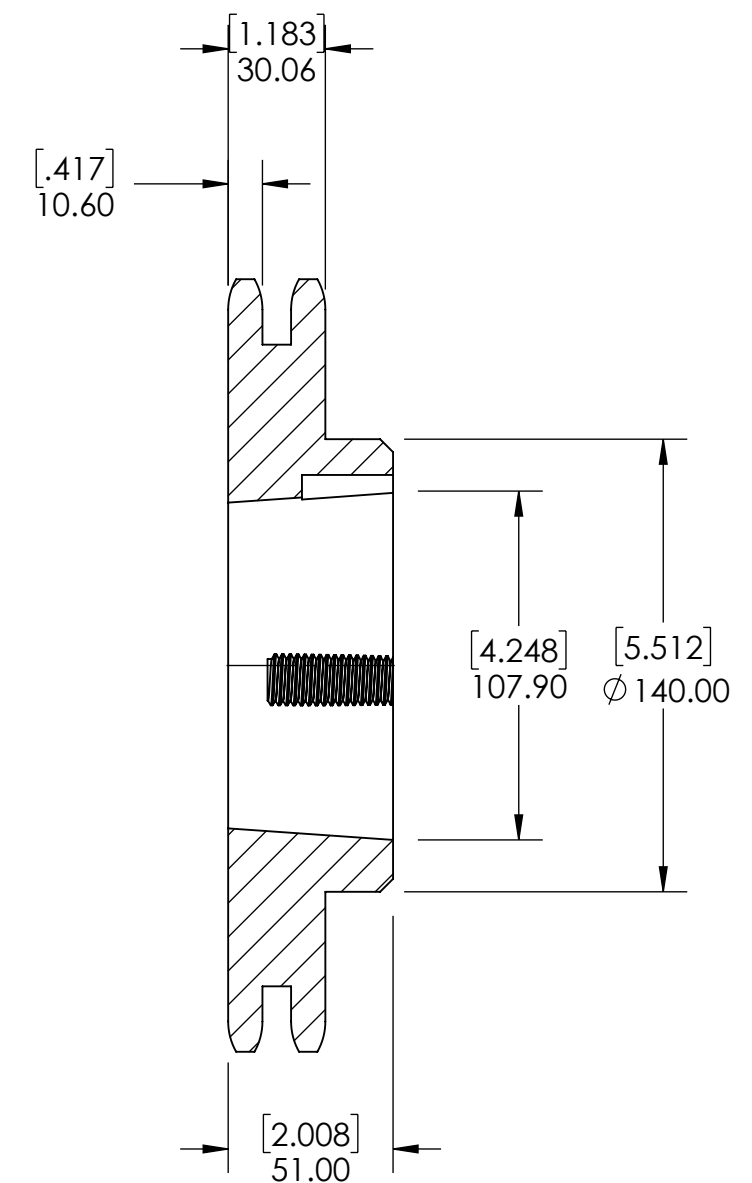
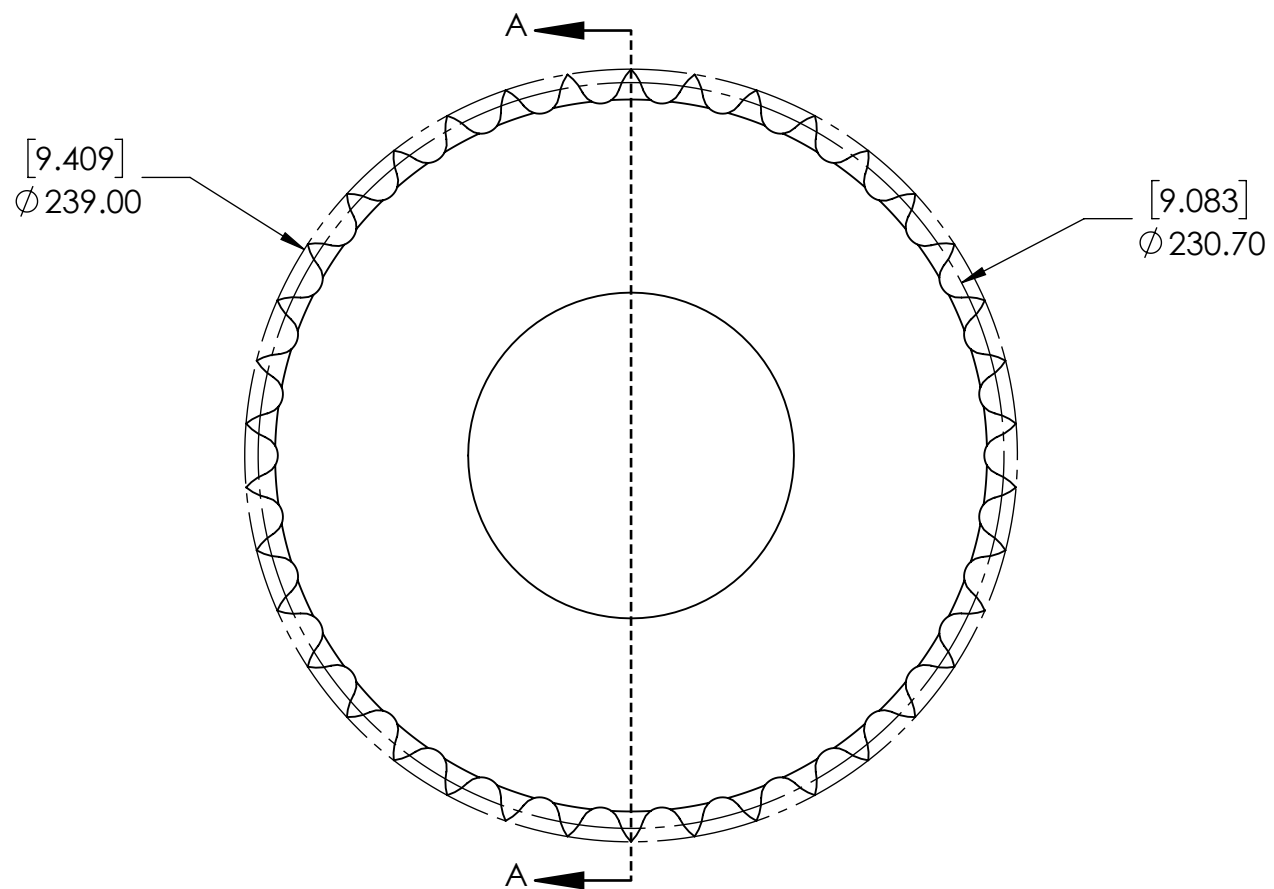

SECTION A-A

SPROCKETS SPECIFICATIONS		WEIGHT		DATE		BY		REVISION DESCRIPTION		REV
UNITS	mm (INCH)	17.24 LBS								
CHAIN SIZE	12B	STEEL								
PITCH	19.05 mm	BLACK OXIDE		08/05/2025						
INNER WIDTH	11.68 mm	DRAWN		SEC						
ROLLER DIA.	12.07 mm	CHECKED		SEC						
TOOTH WIDTH	10.60 mm	APPROVED								
NUMBER OF TEETH	38	THIRD ANGLE PROJECTION								
HUB STYLE	B	DWG. NO.								
BORE TYPE	FOR TAPER BUSHING	PTI		PROPRIETARY AND CONFIDENTIAL						
BUSHING NUMBER	3020	12B-2-38TL-3020		THE INFORMATION CONTAINED IN THIS DRAWING IS THE SOLE PROPERTY OF SOLVE IMG. ANY REPRODUCTION IN PART OR AS A WHOLE WITHOUT THE WRITTEN PERMISSION OF SOLVE IMG IS PROHIBITED.						
ITEM DESCRIPTION:										SCALE
										1:1
										REV
										-

9 8 7 6 5 4 3 2 1