

9 8 7 6 5 4 3 2 1

G
F
E
D
C
B
A

G
F
E
D
C
B
A

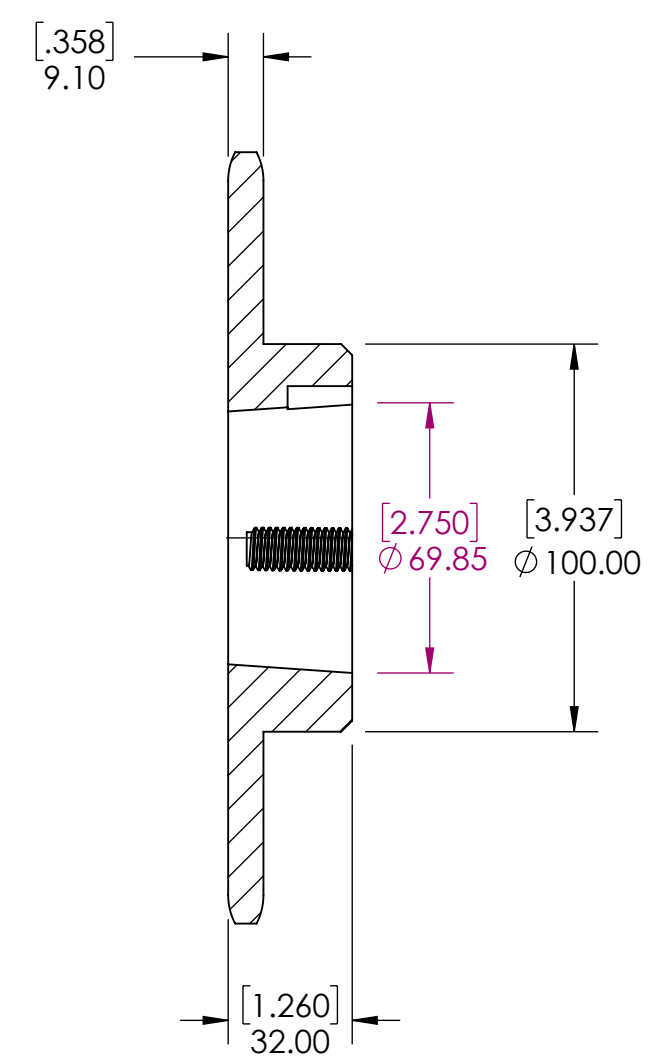
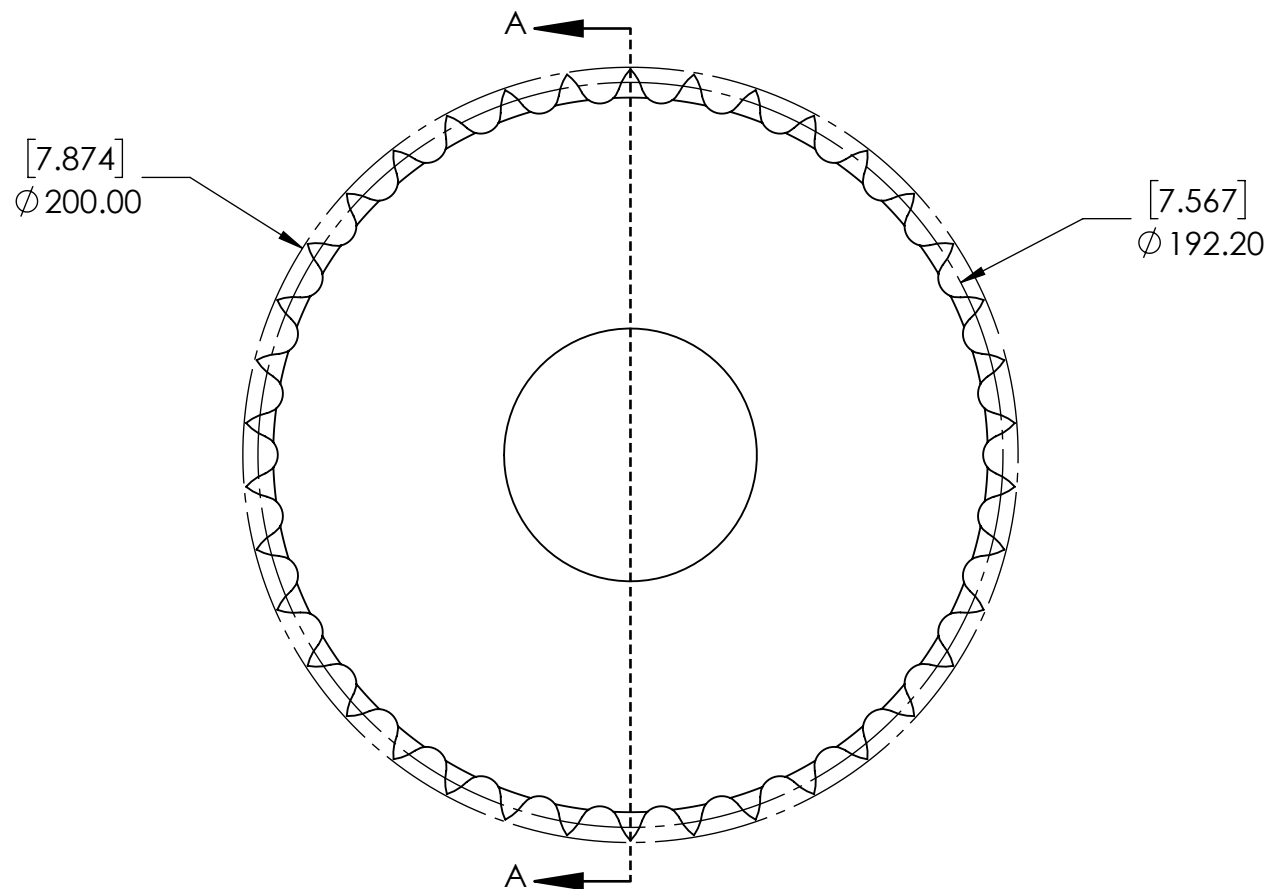

SECTION A-A

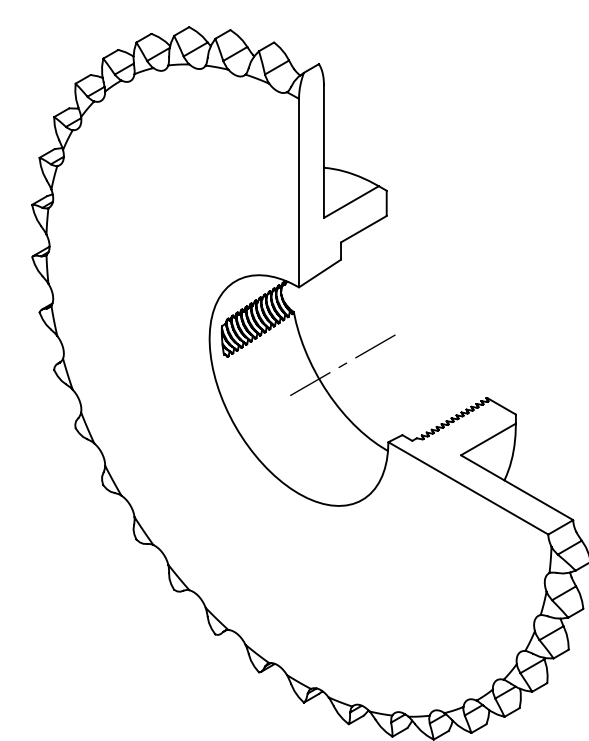

SPROCKETS SPECIFICATIONS		WEIGHT		5.42 LBS	
UNITS	mm (INCH)	MATERIAL	STEEL		
CHAIN SIZE	10B	COATING	BLACK OXIDE		
PITCH	15.88 mm	DRAWN	SEC	07/21/2025	
INNER WIDTH	9.65 mm	CHECKED	EG	07/24/2025	
ROLLER DIA.	10.16 mm	APPROVED			
TOOTH WIDTH	9.10 mm	DATE	BY	REVISION DESCRIPTION	
NUMBER OF TEETH	38	ITEM DESCRIPTION:		10B-38TL-2012	
HUB STYLE	B	DWG. NO.		SCALE	
BORE TYPE	FOR TAPER BUSHING			1:1	
BUSHING NUMBER	2012	PROPRIETARY AND CONFIDENTIAL <small>THE INFORMATION CONTAINED IN THIS DRAWING IS THE SOLE PROPERTY OF SOLVE IMG. ANY REPRODUCTION IN PART OR AS A WHOLE WITHOUT THE WRITTEN PERMISSION OF SOLVE IMG IS PROHIBITED.</small>		REV	
				-	

9 8 7 6 5 4 3 2 1