

9 8 7 6 5 4 3 2 1

G F E D C B A

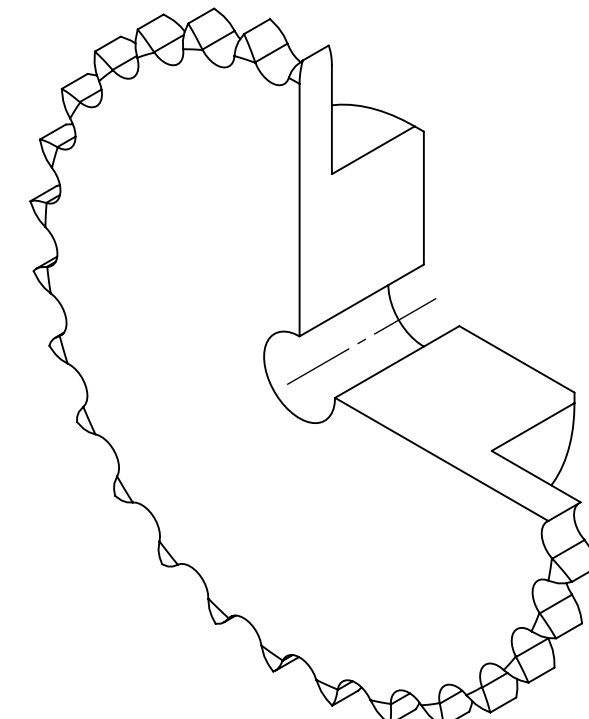
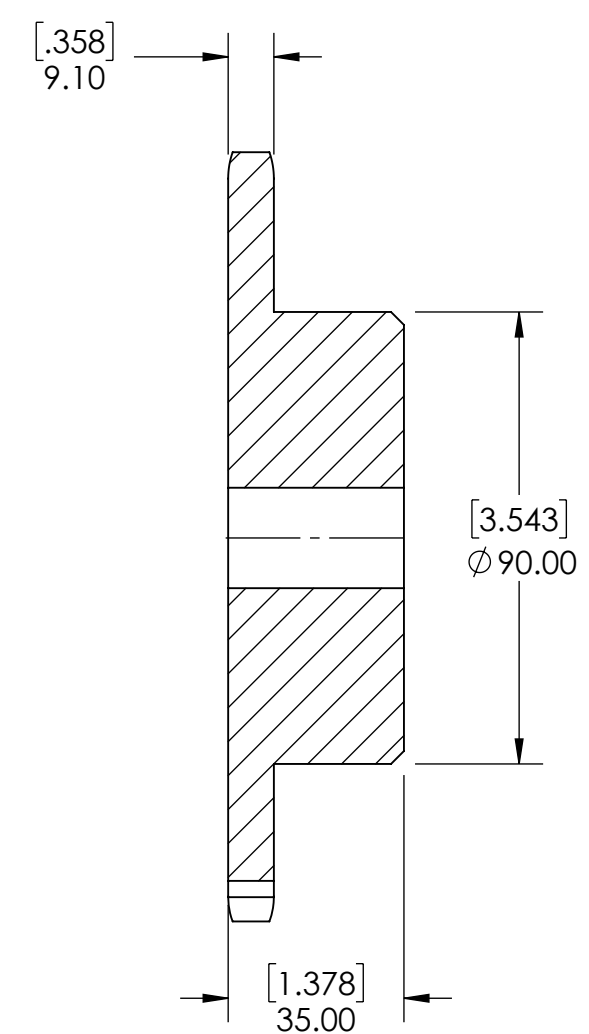
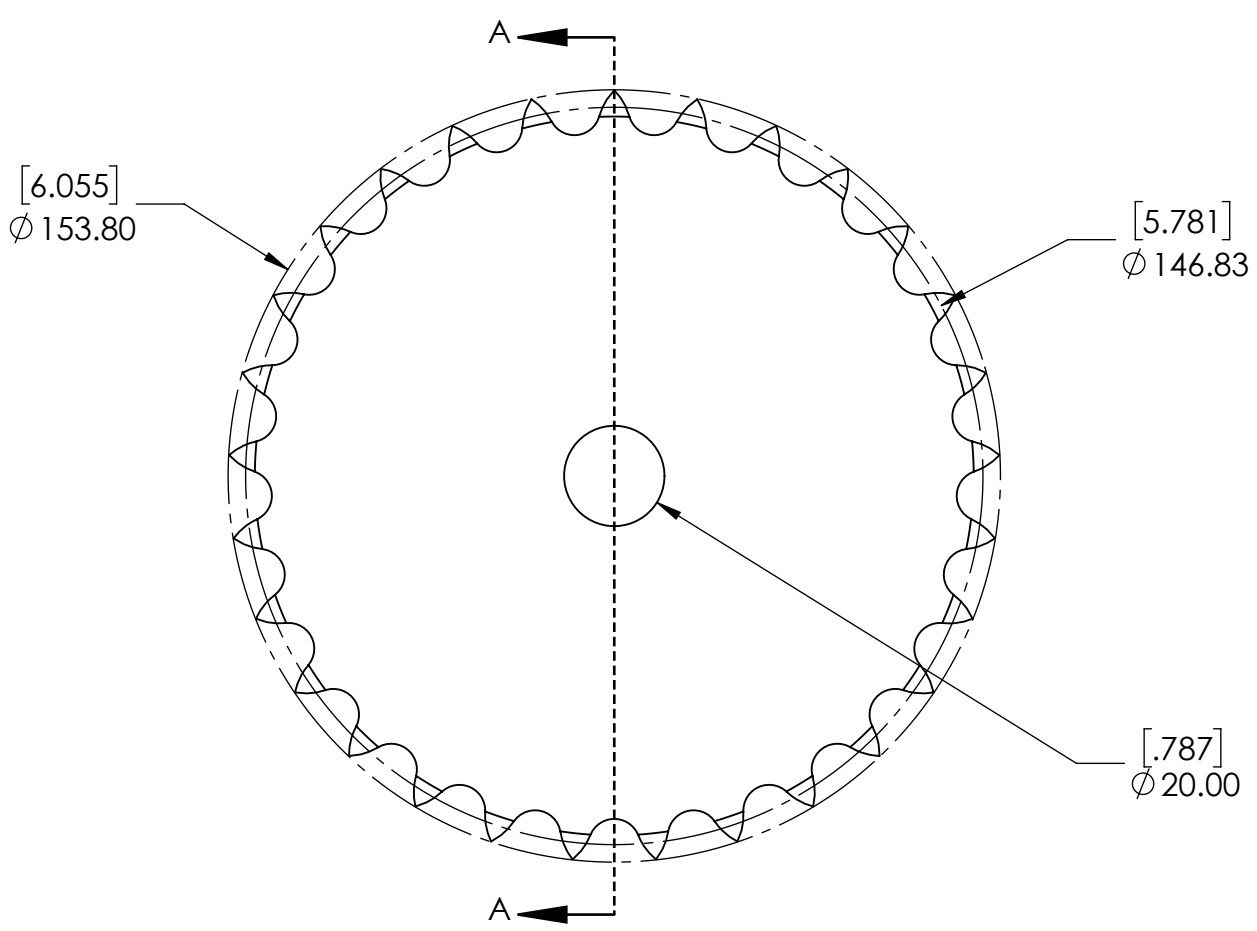

SECTION A-A

SPROCKETS SPECIFICATIONS		WEIGHT		DATE		BY		REVISION DESCRIPTION		REV
UNITS	mm (INCH)	5.16 LBS								
CHAIN SIZE	10B	MATERIAL	STEEL							
PITCH	15.88 mm	COATING	BLACK OXIDE	DRAWN	SEC	07/21/2025				
INNER WIDTH	9.65 mm	CHECKED	EG	07/23/2025						
ROLLER DIA.	10.16 mm	APPROVED								
TOOTH WIDTH	9.10 mm									
NUMBER OF TEETH	29									
HUB STYLE	B									
BORE TYPE	PLAIN BORE									
BUSHING NUMBER	N/A									
		SIZE PTI		DWG. NO.		ITEM DESCRIPTION:		10B-29B		SCALE
										1:1
										REV
										-

A

9 8 7 6 5 4 3 2 1