

9 8 7 6 5 4 3 2 1

G  
F  
E  
D  
C  
B  
A

G  
F  
E  
D  
C  
B  
A

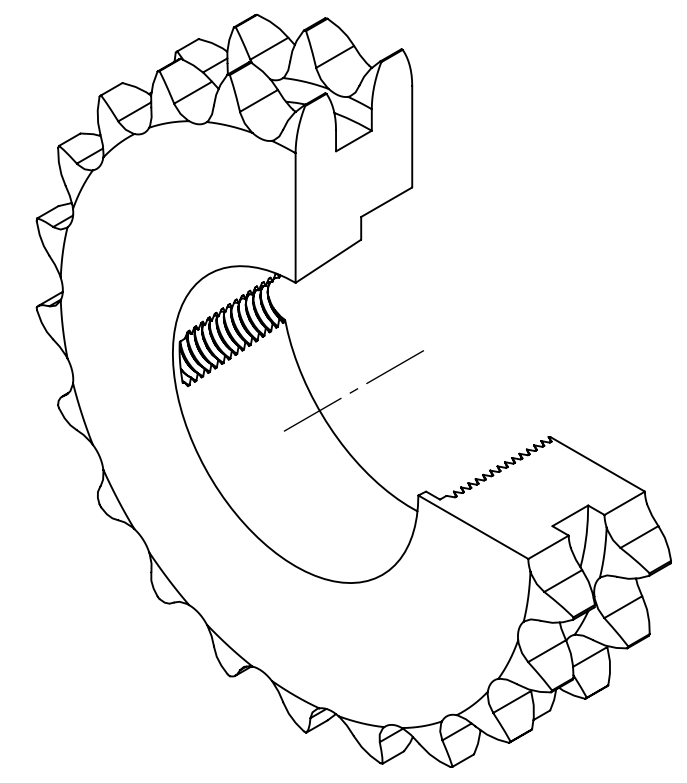
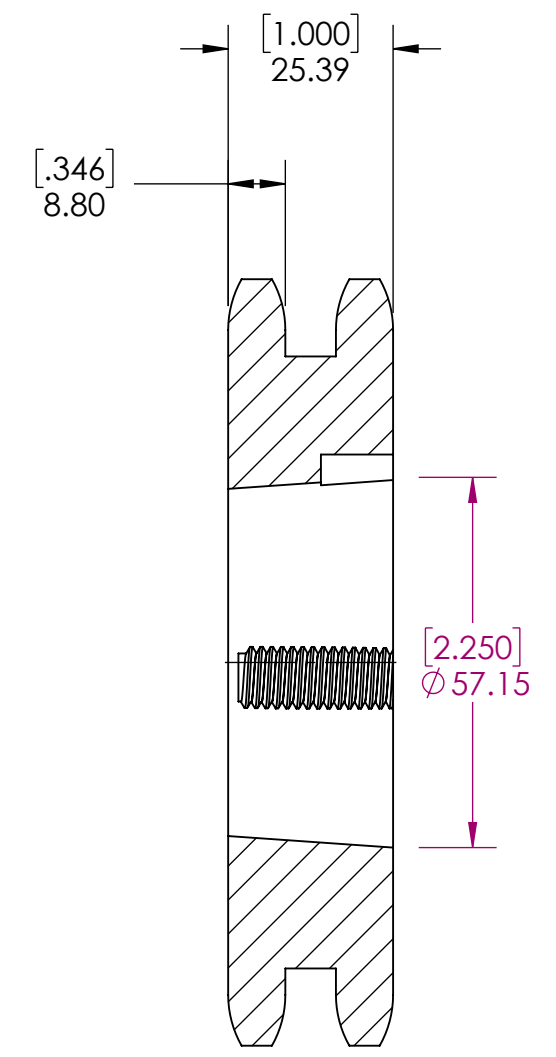
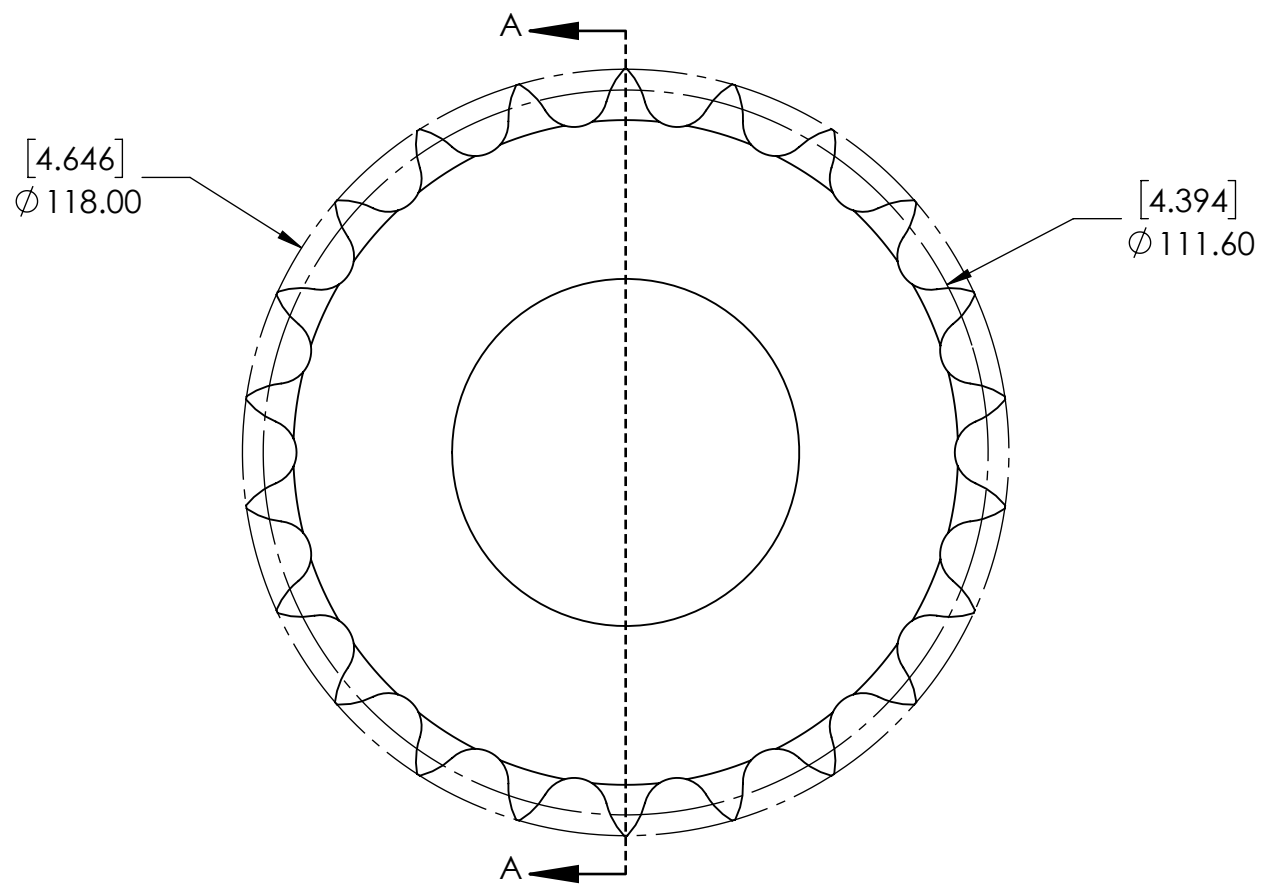

SECTION A-A

SPROCKETS SPECIFICATIONS		WEIGHT		DATE		BY		REVISION DESCRIPTION		REV
UNITS	mm (INCH)	2.60 LBS								
CHAIN SIZE	10B	STEEL								
PITCH	15.88 mm	BLACK OXIDE		07/30/2025						
INNER WIDTH	9.65 mm	DRAWN		EG						
ROLLER DIA.	10.16 mm	CHECKED		EG						
TOOTH WIDTH	8.80 mm	APPROVED								
NUMBER OF TEETH	22									
HUB STYLE	A									
BORE TYPE	FOR TAPER BUSHING	DWG. NO.		10B-2-22TL-1610						
BUSHING NUMBER	1610			<small>PROPRIETARY AND CONFIDENTIAL</small> <small>THE INFORMATION CONTAINED IN THIS DRAWING IS THE SOLE PROPERTY OF SOLVE IMG. ANY REPRODUCTION IN PART OR AS A WHOLE WITHOUT THE WRITTEN PERMISSION OF SOLVE IMG IS PROHIBITED.</small>						
ITEM DESCRIPTION: 10B-2-22TL-1610										
										SCALE
										1:1
										REV
										-

9 8 7 6 5 4 3 2 1