

9 8 7 6 5 4 3 2 1

G

F

E

D

C

B

A

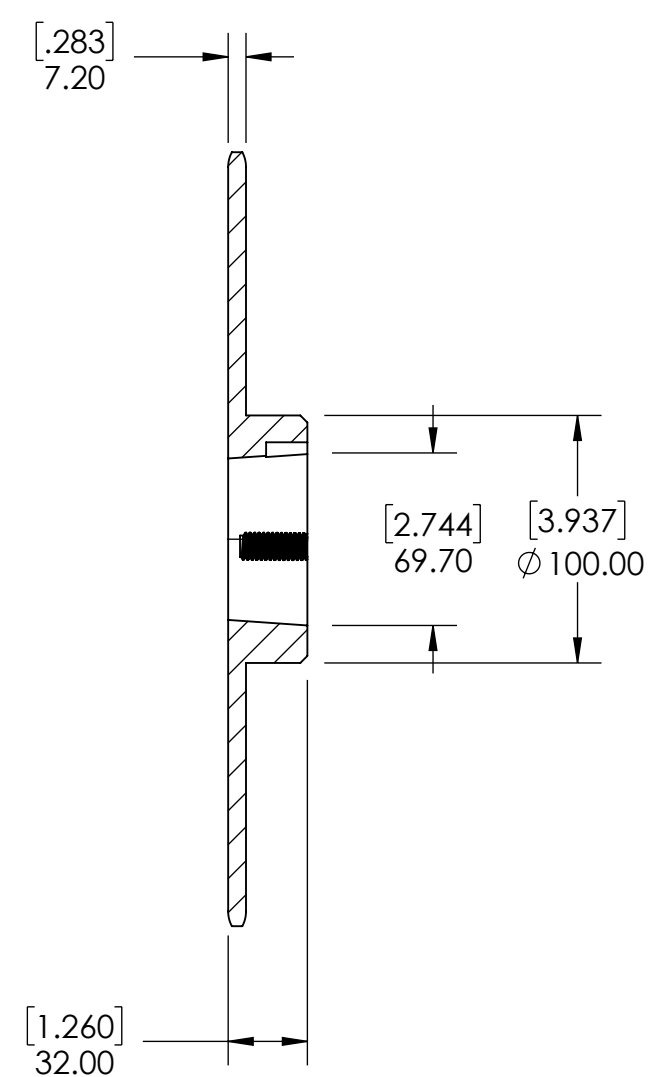
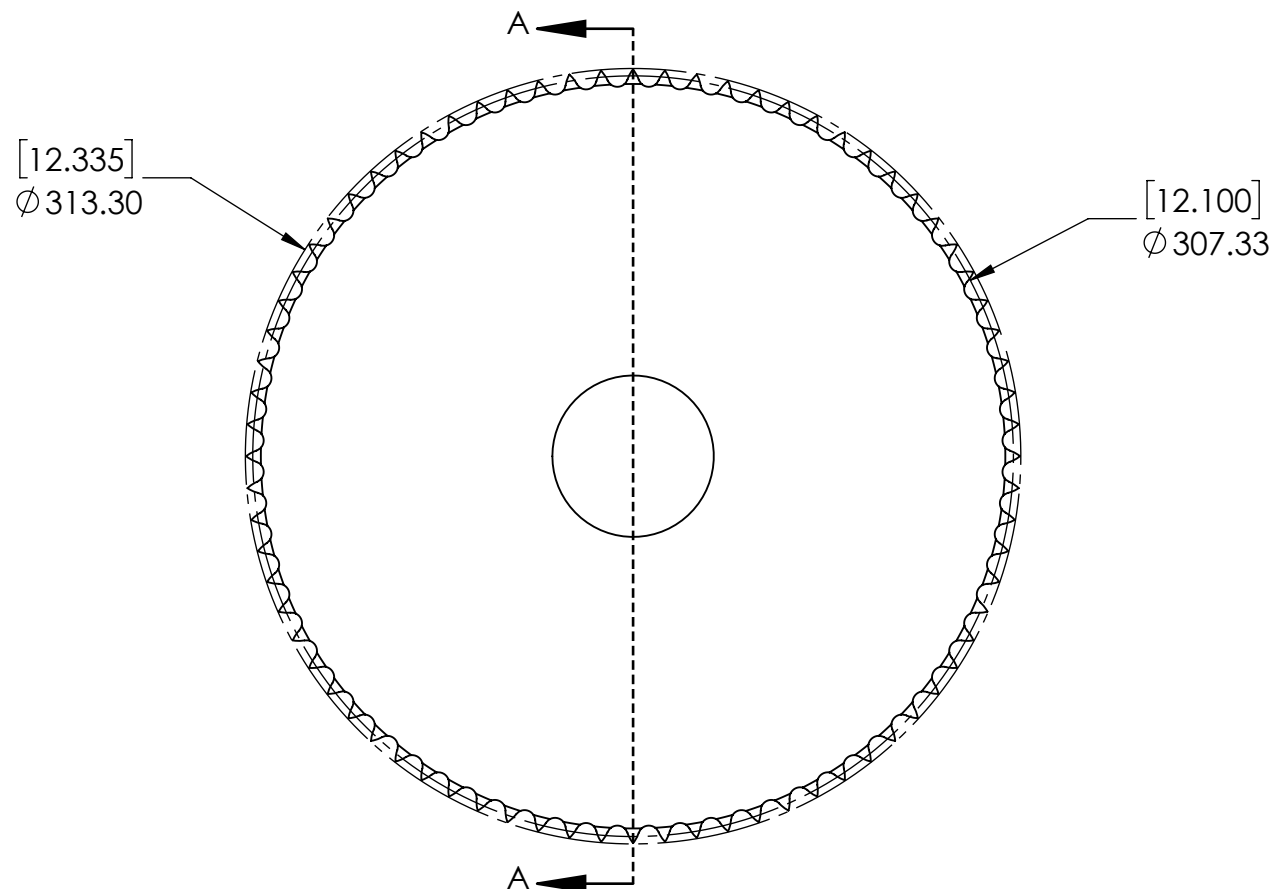

SECTION A-A

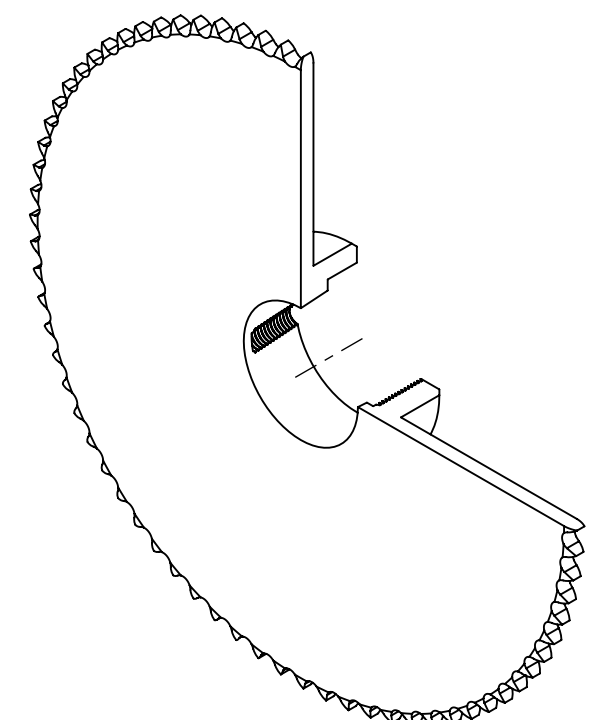

SPROCKETS SPECIFICATIONS		WEIGHT		10.32 LBS	
UNITS	mm (INCH)	MATERIAL	STEEL		
CHAIN SIZE	08B	COATING	BLACK OXIDE		
PITCH	12.70 mm	DRAWN	SEC	07/21/2025	
INNER WIDTH	7.75 mm	CHECKED	SEC	07/30/2025	
ROLLER DIA.	8.51 mm	APPROVED			
TOOTH WIDTH	7.20 mm	DATE		BY	REVISION DESCRIPTION
NUMBER OF TEETH	76	ITEM DESCRIPTION:		08B-76TL-2012	
HUB STYLE	B	DWG. NO.		REV	
BORE TYPE	FOR TAPER BUSHING	<small>PROPRIETARY AND CONFIDENTIAL</small> <small>THE INFORMATION CONTAINED IN THIS DRAWING IS THE SOLE PROPERTY OF SOLVE IMG. ANY REPRODUCTION IN PART OR AS A WHOLE WITHOUT THE WRITTEN PERMISSION OF SOLVE IMG IS PROHIBITED.</small>		SCALE	
BUSHING NUMBER	2012			1:1	
				REV	
				-	

9 8 7 6 5 4 3 2 1