

9 8 7 6 5 4 3 2 1

G  
F  
E  
D  
C  
B  
A

G  
F  
E  
D  
C  
B  
A

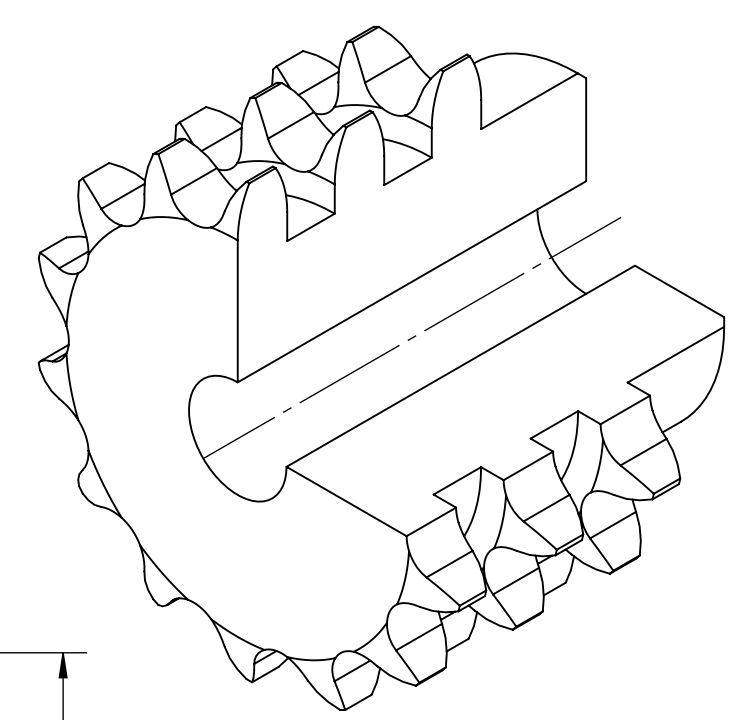
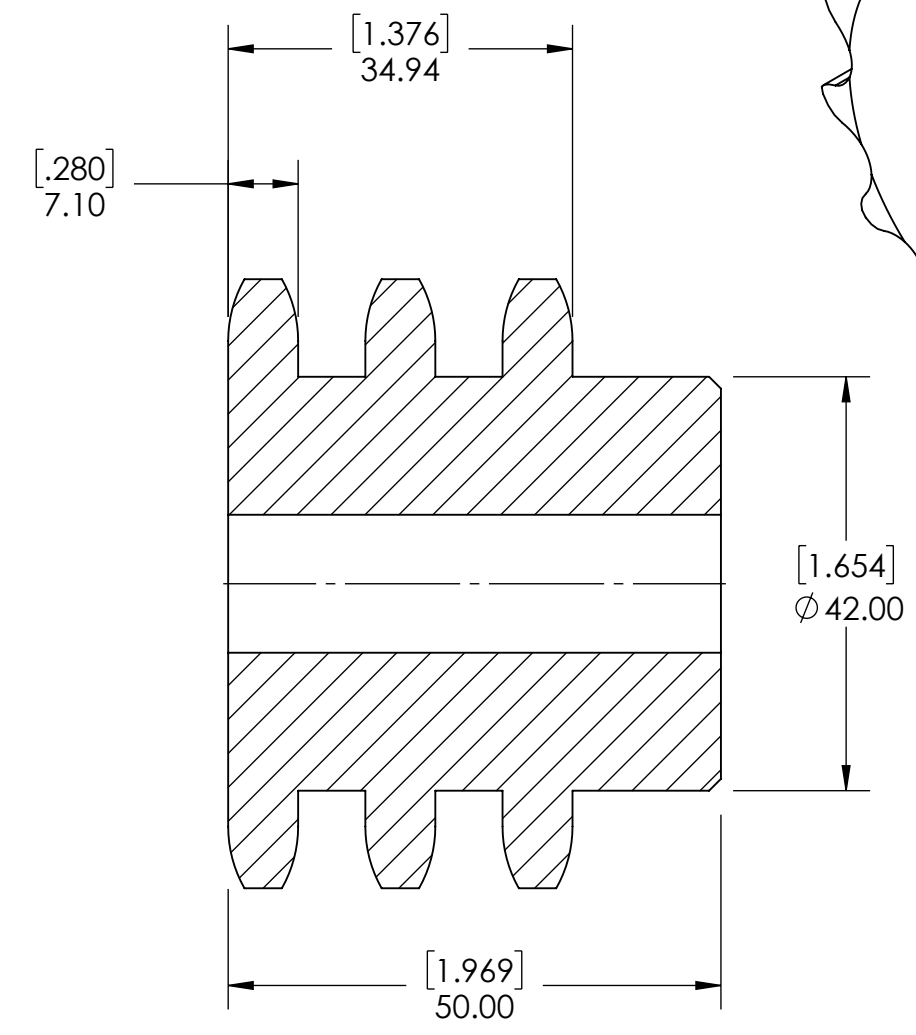
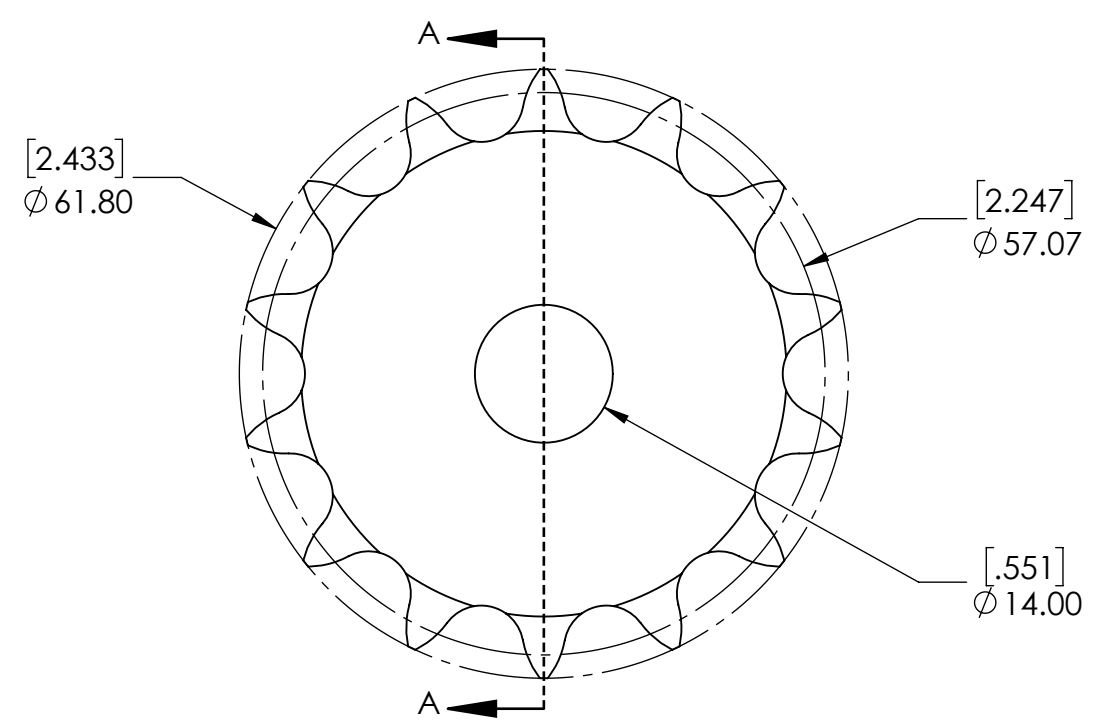

SECTION A-A

SPROCKETS SPECIFICATIONS		WEIGHT		1.37 LBS	
UNITS	mm (INCH)	MATERIAL	STEEL		
CHAIN SIZE	08B	COATING	BLACK OXIDE		
PITCH	12.70 mm	DRAWN	SEC	07/30/2025	
INNER WIDTH	7.75 mm	CHECKED	EG	07/30/2025	
ROLLER DIA.	8.51 mm	APPROVED			
TOOTH WIDTH	7.10 mm	THIRD ANGLE PROJECTION			
NUMBER OF TEETH	14	DATE	BY	REVISION DESCRIPTION	
HUB STYLE	B				
BORE TYPE	PLAIN BORE				
BUSHING NUMBER	N/A				
 INDUSTRIAL MOTION GROUP		 PTI		DWG. NO. <b>08B-3-14B</b>	
		PROPRIETARY AND CONFIDENTIAL <small>THE INFORMATION CONTAINED IN THIS DRAWING IS THE SOLE PROPERTY OF SOLVE IMG. ANY REPRODUCTION IN PART OR AS A WHOLE WITHOUT THE WRITTEN PERMISSION OF SOLVE IMG IS PROHIBITED.</small>		SCALE 1:1	

9 8 7 6 5 4 3 2 1