

9 8 7 6 5 4 3 2 1

G
F
E
D
C
B
A

G
F
E
D
C
B
A

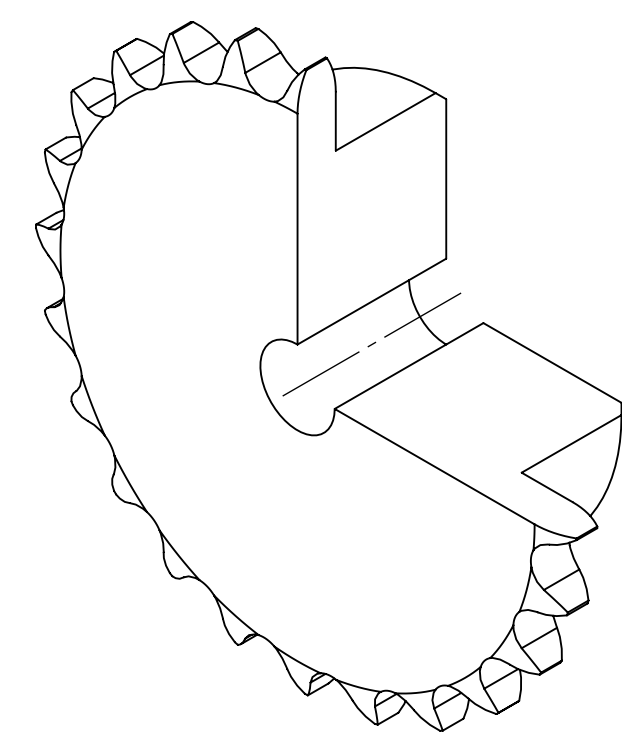
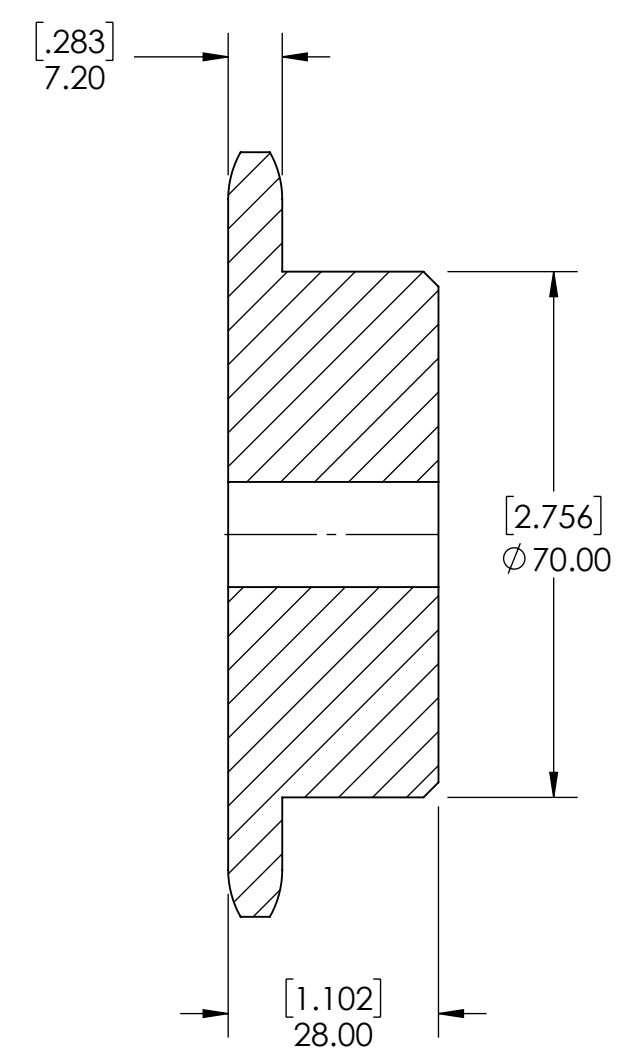
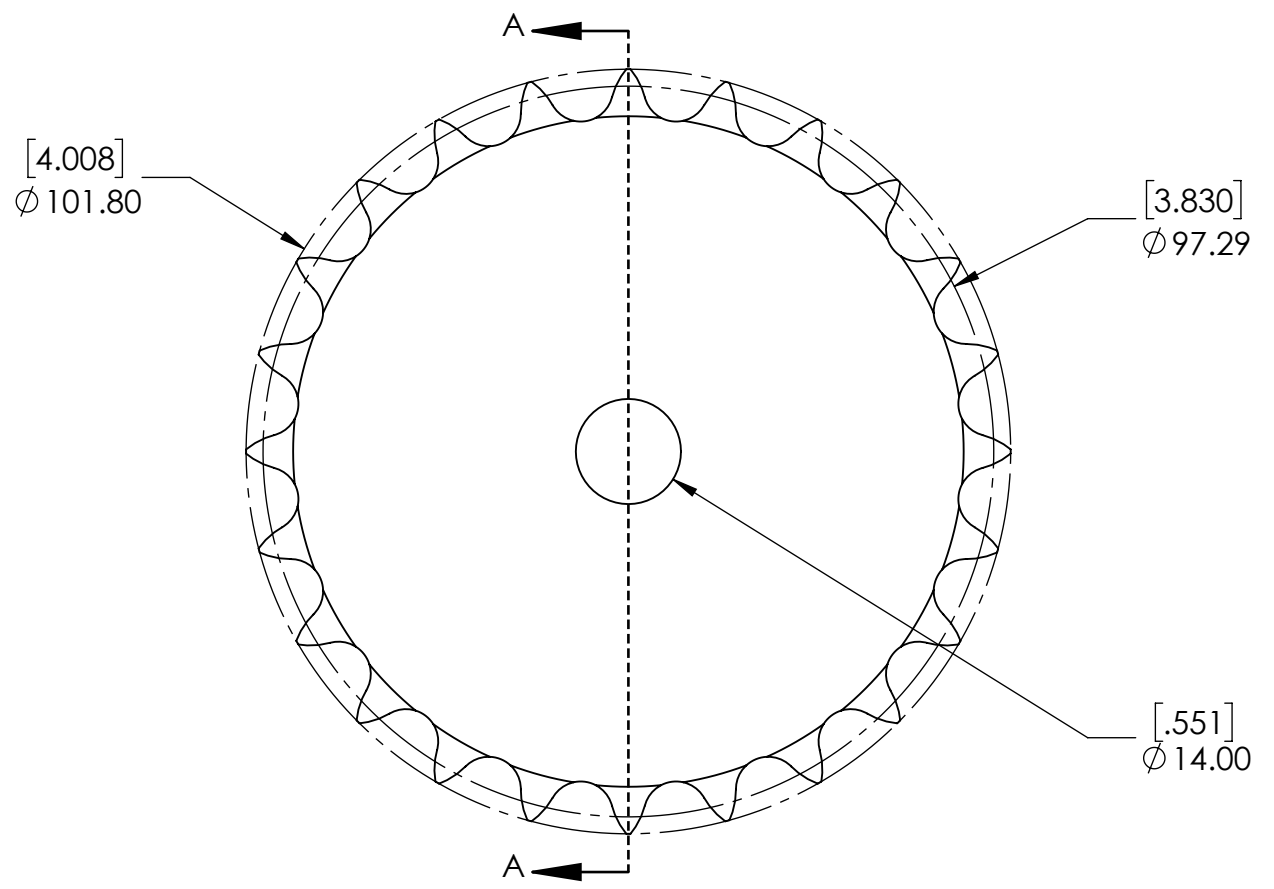

SECTION A-A

NOTES:
1. HARDENED TEETH.

SPROCKETS SPECIFICATIONS		WEIGHT		2.15 LBS	
UNITS	mm (INCH)	MATERIAL	STEEL		
CHAIN SIZE	08B	COATING	BLACK OXIDE		
PITCH	12.70 mm	DRAWN	SEC	07/21/2025	
INNER WIDTH	7.75 mm	CHECKED	PT	07/24/2025	
ROLLER DIA.	8.51 mm	APPROVED			
TOOTH WIDTH	7.20 mm	DATE	BY	REVISION DESCRIPTION	
NUMBER OF TEETH	24	ITEM DESCRIPTION:			REV
HUB STYLE	B	08B-24BH			SCALE
BORE TYPE	PLAIN BORE				1:1
BUSHING NUMBER	N/A				REV
		DWG. NO.		-	

9 8 7 6 5 4 3 2 1

A