

9 8 7 6 5 4 3 2 1

G
F
E
D
C
B
A

G
F
E
D
C
B
A

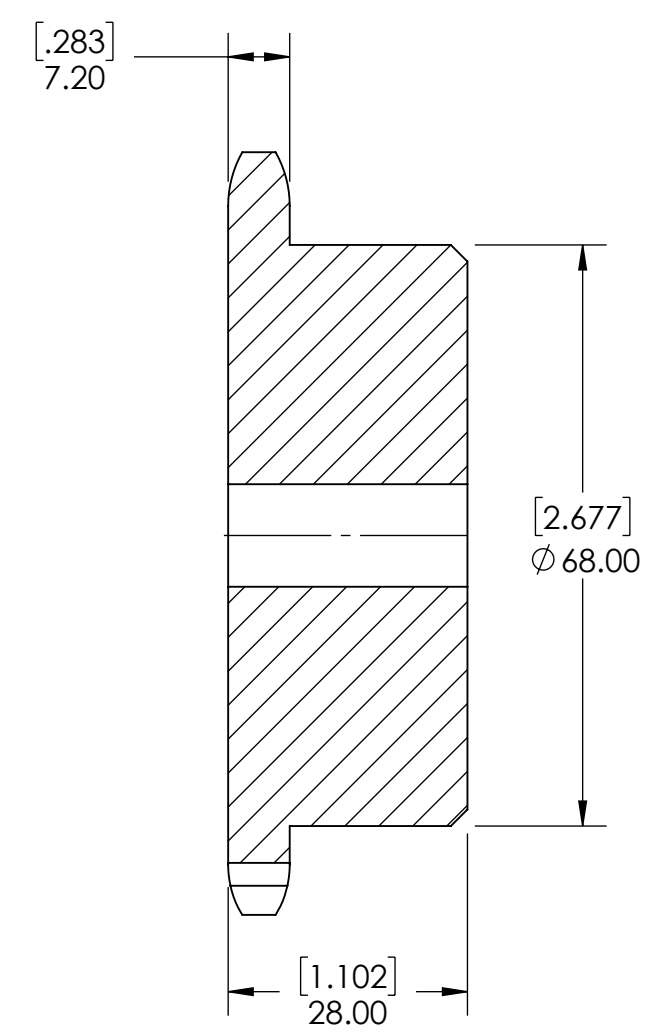
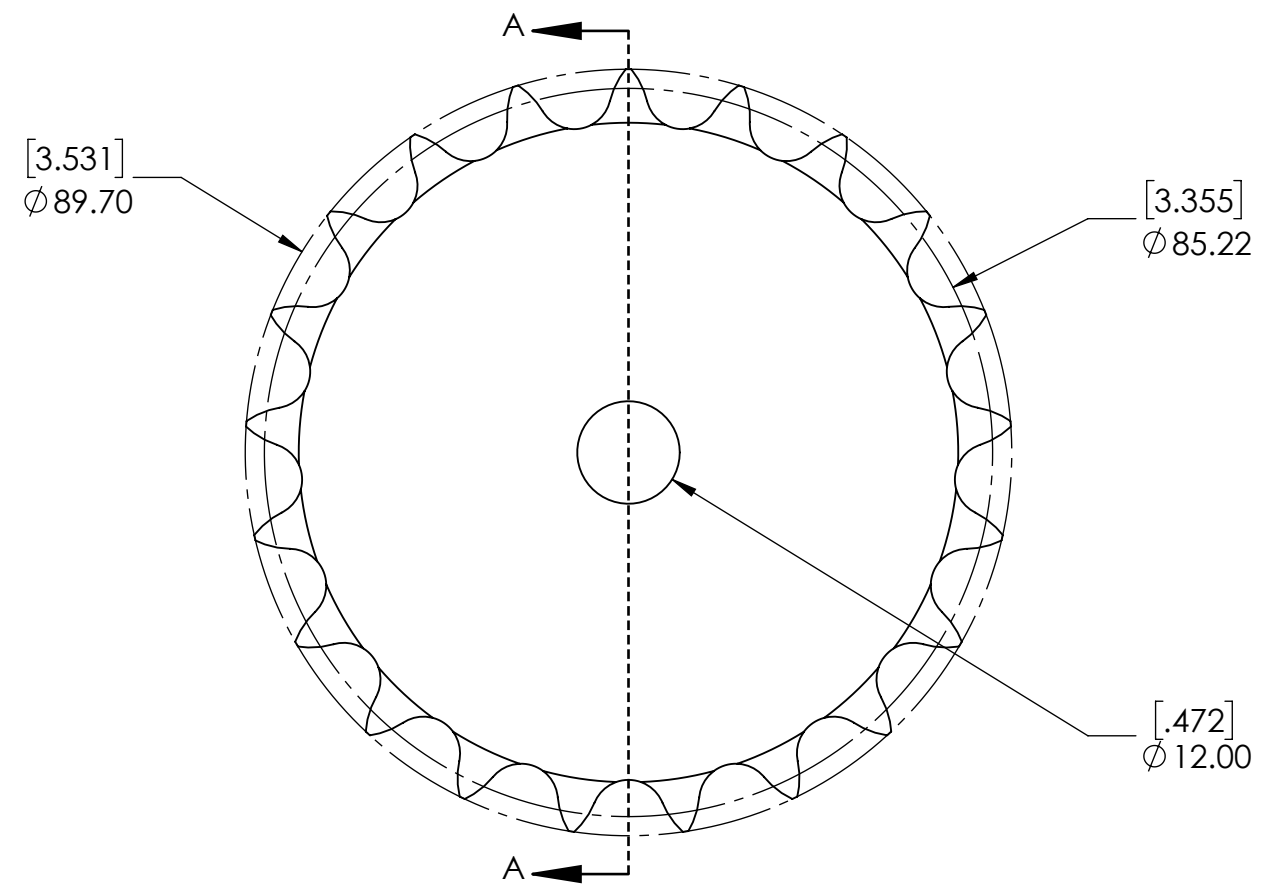

SECTION A-A

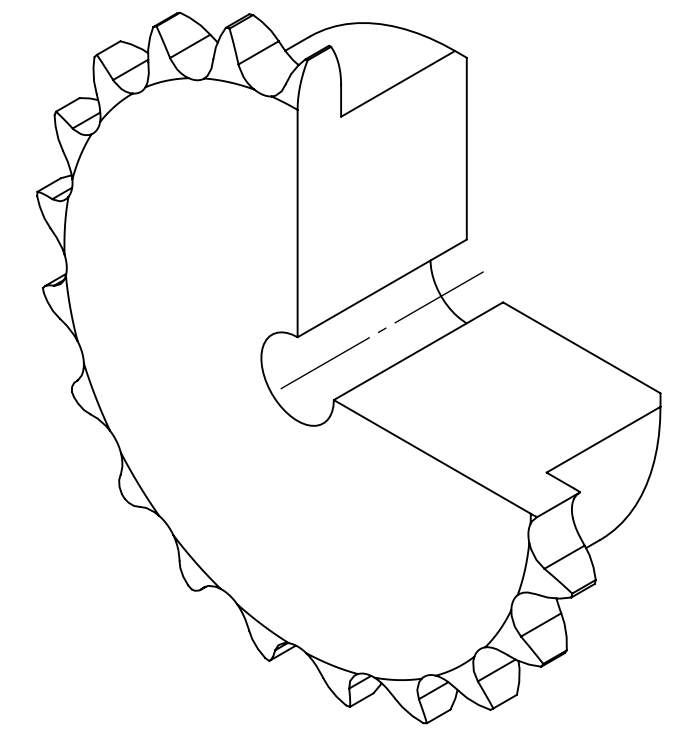

SPROCKETS SPECIFICATIONS		WEIGHT		1.92 LBS	
UNITS	mm (INCH)	MATERIAL	STAINLESS STEEL		
CHAIN SIZE	08B	COATING	N/A		
PITCH	12.70 mm	DRAWN	SEC	07/21/2025	
INNER WIDTH	7.75 mm	CHECKED			
ROLLER DIA.	8.51 mm	APPROVED			
TOOTH WIDTH	7.20 mm				
NUMBER OF TEETH	21				
HUB STYLE	B				
BORE TYPE	PLAIN BORE				
BUSHING NUMBER	N/A				

DATE	BY	REVISION DESCRIPTION	REV
ITEM DESCRIPTION:			SCALE
08B-21BSS			1:1
			REV
			-

9 8 7 6 5 4 3 2 1