

9 8 7 6 5 4 3 2 1

G
F
E
D
C
B
A

G
F
E
D
C
B
A

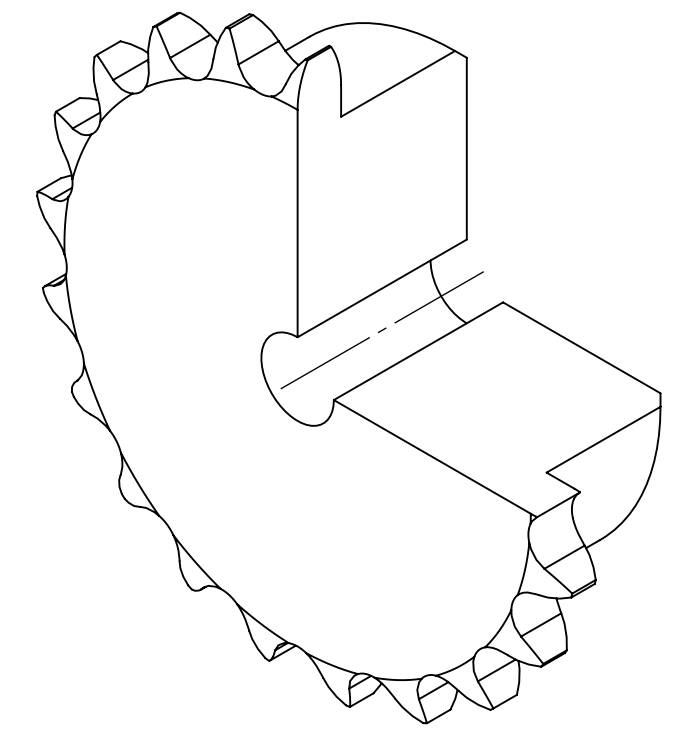
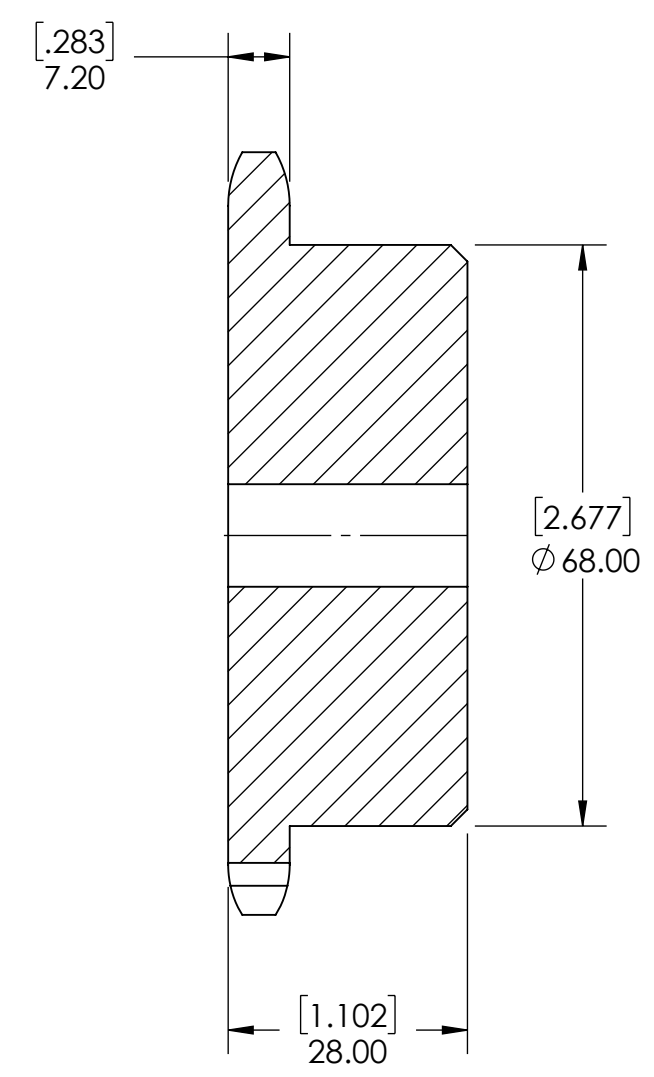
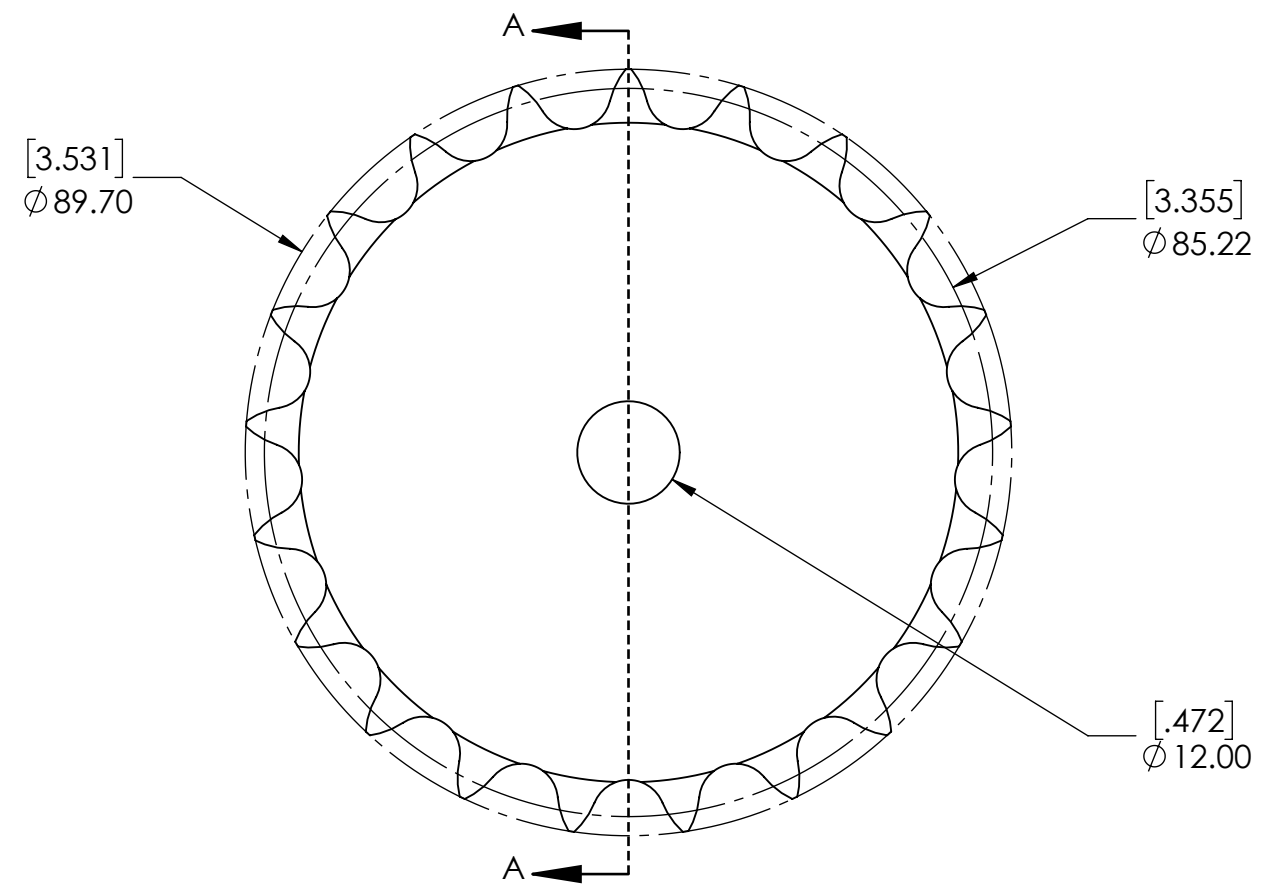

SECTION A-A

NOTES:
1. HARDENED TEETH.

SPROCKETS SPECIFICATIONS		WEIGHT		1.89 LBS		
UNITS	mm (INCH)	MATERIAL	STEEL			
CHAIN SIZE	08B	COATING	BLACK OXIDE			
PITCH	12.70 mm	DRAWN	SEC	07/21/2025		
INNER WIDTH	7.75 mm	CHECKED				
ROLLER DIA.	8.51 mm	APPROVED				
TOOTH WIDTH	7.20 mm	THIRD ANGLE PROJECTION		DATE	BY	
NUMBER OF TEETH	21			REVISION DESCRIPTION		REV
HUB STYLE	B			ITEM DESCRIPTION:		SCALE
BORE TYPE	PLAIN BORE	DWG. NO.		08B-21BH		1:1
BUSHING NUMBER	N/A			<small>PROPRIETARY AND CONFIDENTIAL THE INFORMATION CONTAINED IN THIS DRAWING IS THE SOLE PROPERTY OF SOLVE IMG. ANY REPRODUCTION IN PART OR AS A WHOLE WITHOUT THE WRITTEN PERMISSION OF SOLVE IMG IS PROHIBITED.</small>		REV -

9 8 7 6 5 4 3 2 1