

9 8 7 6 5 4 3 2 1

G
F
E
D
C
B
A

G
F
E
D
C
B
A

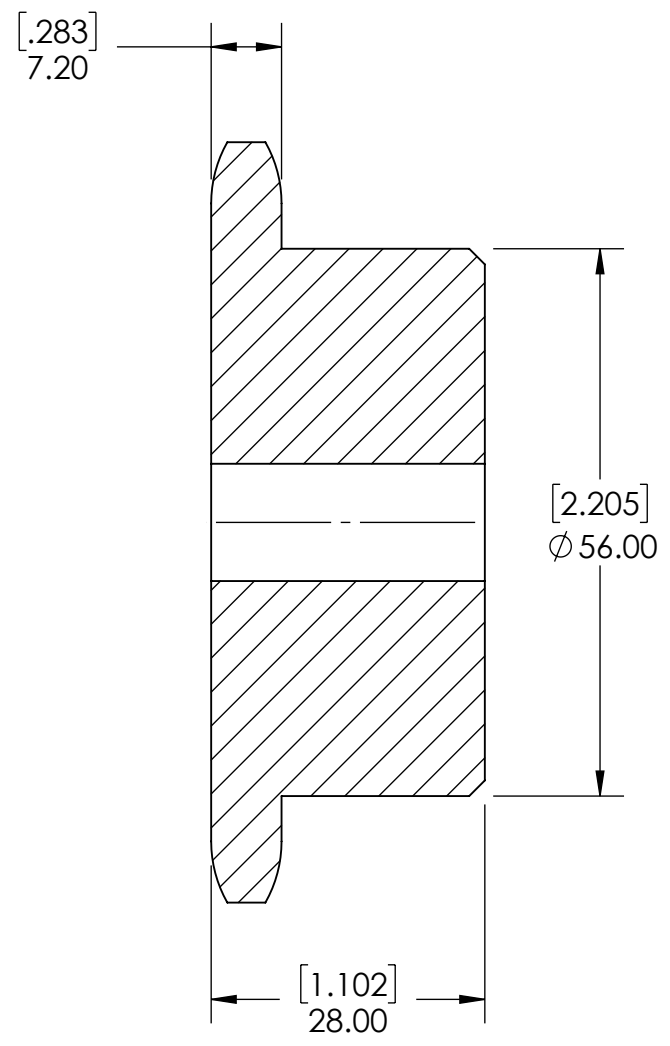
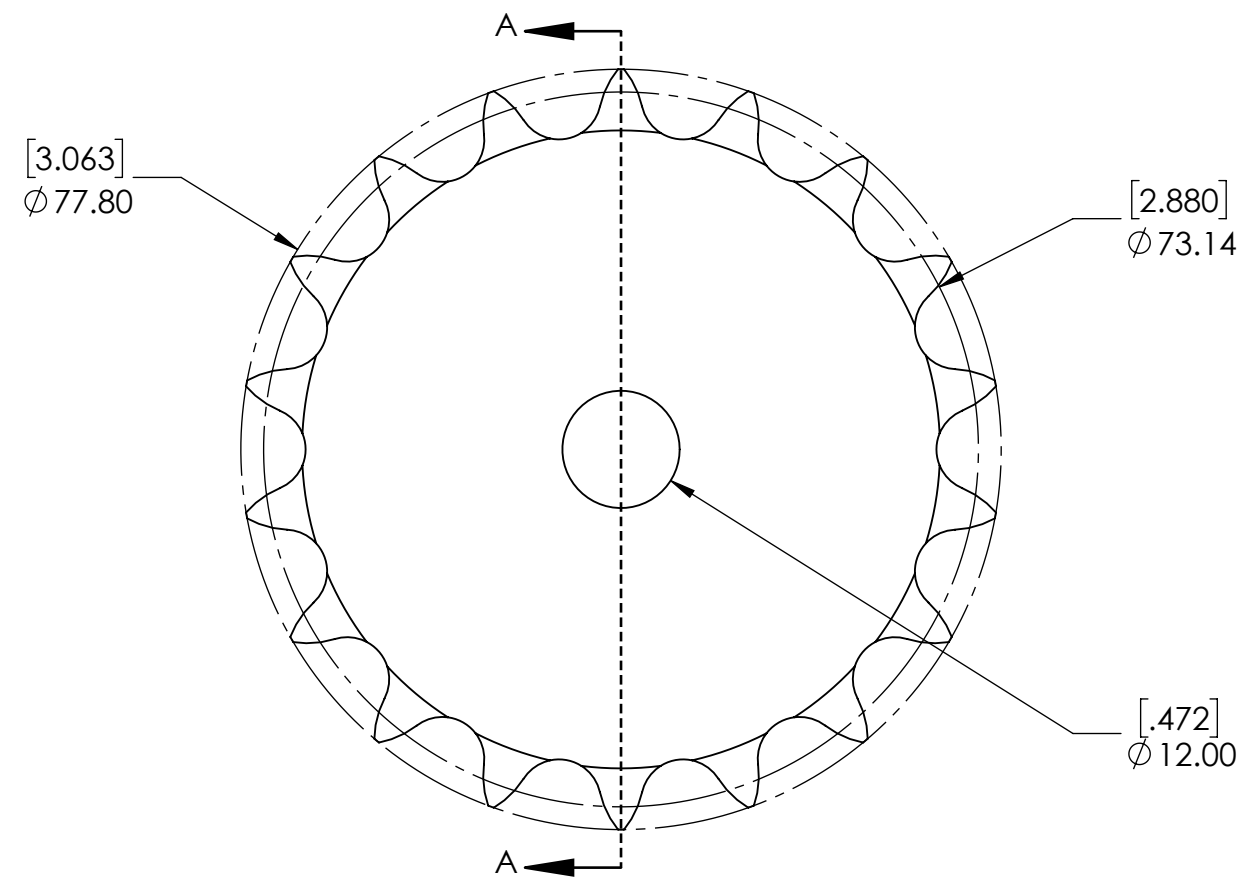

SECTION A-A

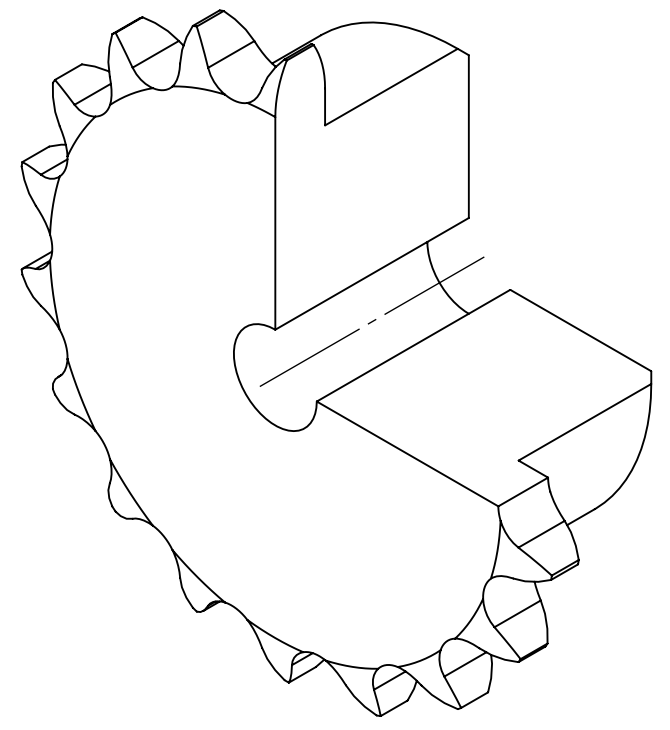

NOTES:
1. HARDENED TEETH.

SPROCKETS SPECIFICATIONS		WEIGHT		1.29 LBS	
UNITS	mm (INCH)	MATERIAL	STEEL		
CHAIN SIZE	08B	COATING	BLACK OXIDE		
PITCH	12.70 mm	DRAWN	SEC	07/21/2025	
INNER WIDTH	7.75 mm	CHECKED	PT	07/24/2025	
ROLLER DIA.	8.51 mm	APPROVED			
TOOTH WIDTH	7.20 mm	THIRD ANGLE PROJECTION		DATE	BY
NUMBER OF TEETH	18			REVISION DESCRIPTION	
HUB STYLE	B	DWG. NO.		ITEM DESCRIPTION:	
BORE TYPE	PLAIN BORE	PROPRIETARY AND CONFIDENTIAL <small>THE INFORMATION CONTAINED IN THIS DRAWING IS THE SOLE PROPERTY OF SOLVE IMG. ANY REPRODUCTION IN PART OR AS A WHOLE WITHOUT THE WRITTEN PERMISSION OF SOLVE IMG IS PROHIBITED.</small>		08B-18BH	
BUSHING NUMBER	N/A	REV		SCALE	
		-		1:1	

9 8 7 6 5 4 3 2 1