

9 8 7 6 5 4 3 2 1

G
F
E
D
C
B
A

G
F
E
D
C
B
A

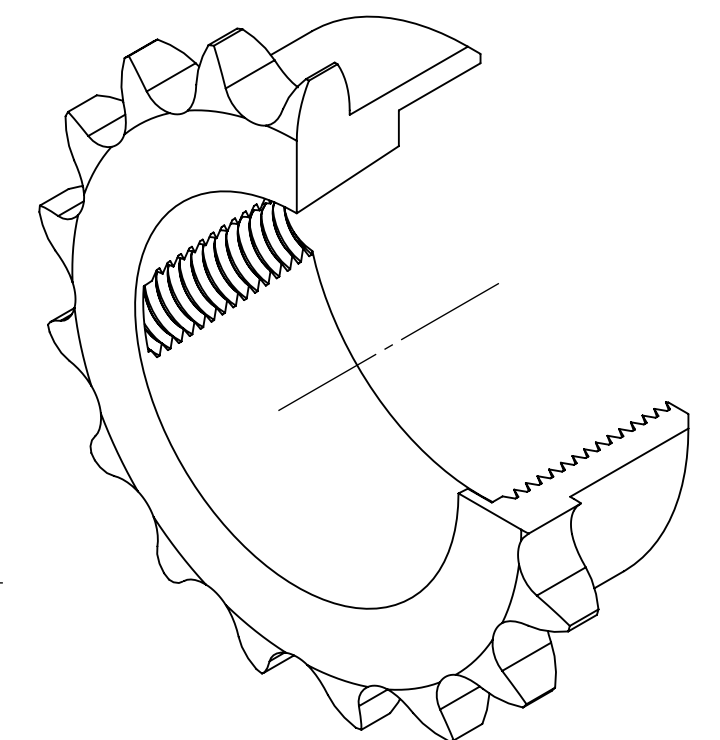
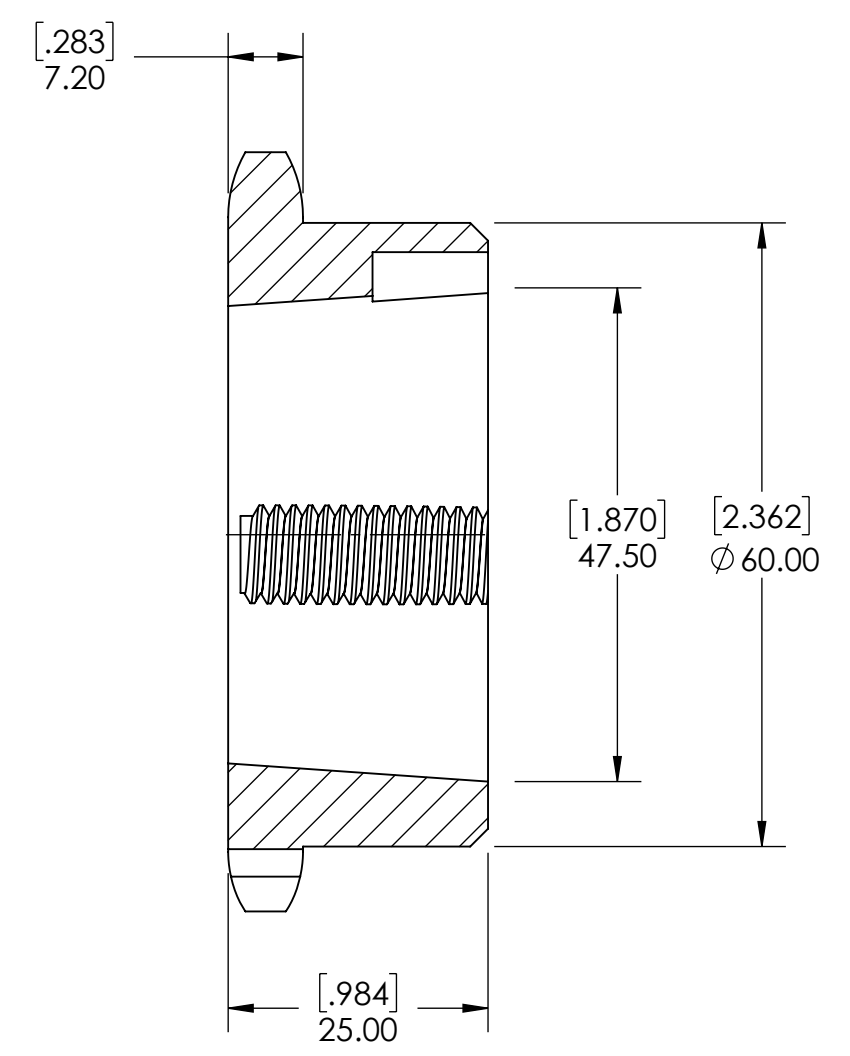
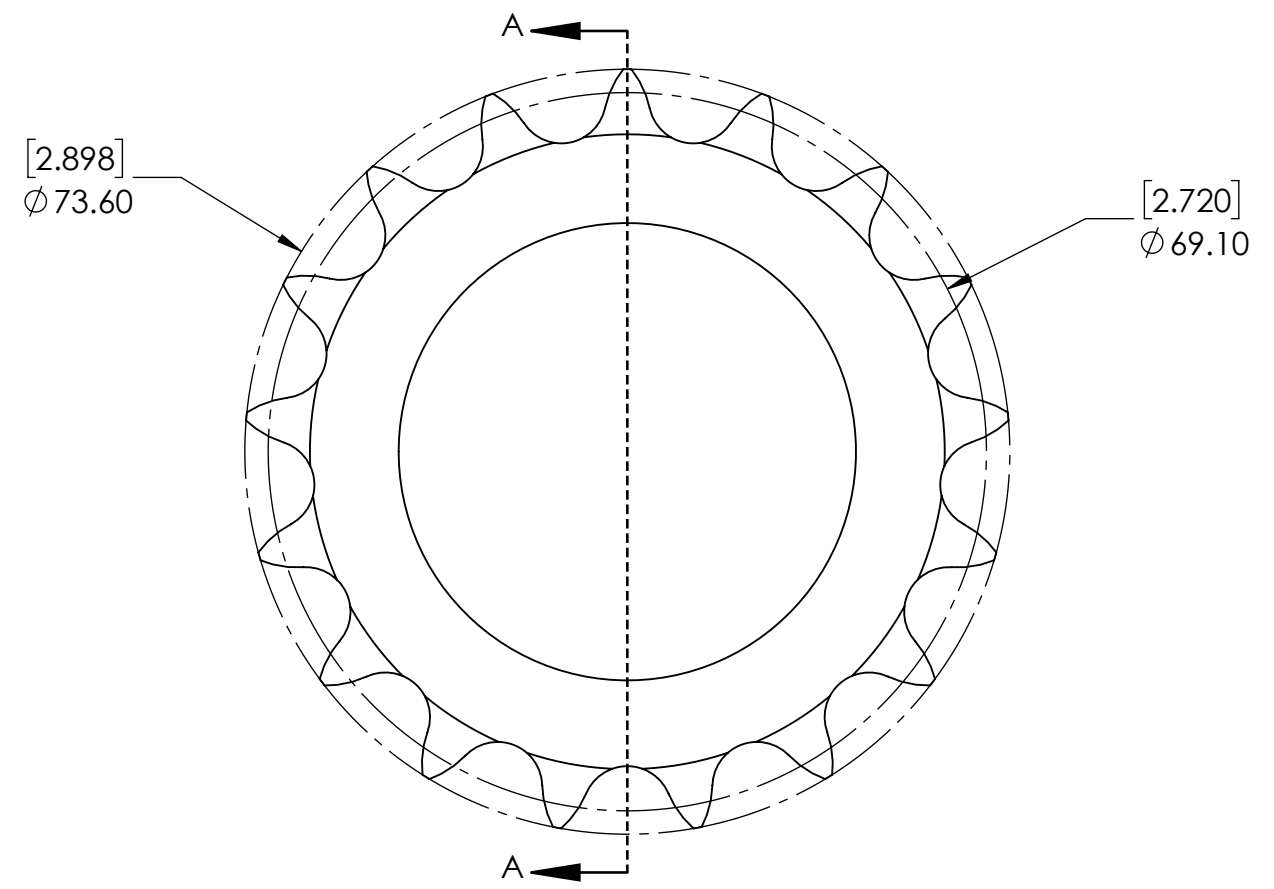

NOTES:
1. HARDENED TEETH.

SPROCKETS SPECIFICATIONS		WEIGHT		DATE		BY		REVISION DESCRIPTION		REV
UNITS	mm (INCH)	0.54 LBS								SCALE
CHAIN SIZE	08B	MATERIAL	STEEL							1:1
PITCH	12.70 mm	COATING	BLACK OXIDE							REV
INNER WIDTH	7.75 mm	DRAWN	SEC 07/21/2025							-
ROLLER DIA.	8.51 mm	CHECKED	SEC 07/28/2025							
TOOTH WIDTH	7.20 mm	APPROVED								
NUMBER OF TEETH	17			ITEM DESCRIPTION:						
HUB STYLE	B			08B-17HTL-1210						
BORE TYPE	FOR TAPER BUSHING	DWG. NO.		PROPRIETARY AND CONFIDENTIAL						
BUSHING NUMBER	1210	SIZE PTI		<small>THE INFORMATION CONTAINED IN THIS DRAWING IS THE SOLE PROPERTY OF SOLVE IMG. ANY REPRODUCTION IN PART OR AS A WHOLE WITHOUT THE WRITTEN PERMISSION OF SOLVE IMG IS PROHIBITED.</small>						

9 8 7 6 5 4 3 2 1