

9 8 7 6 5 4 3 2 1

G  
F  
E  
D  
C  
B  
A

G  
F  
E  
D  
C  
B  
A

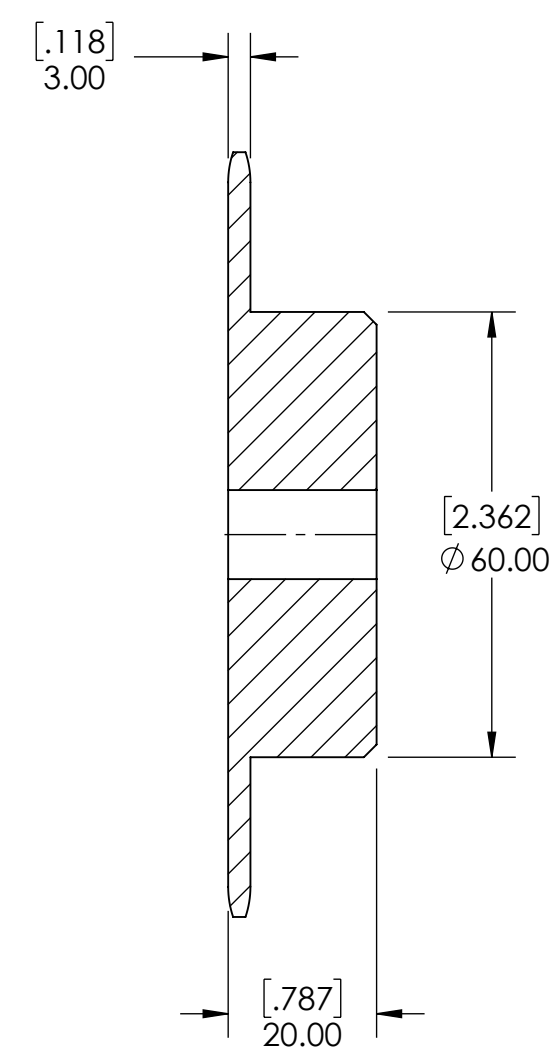
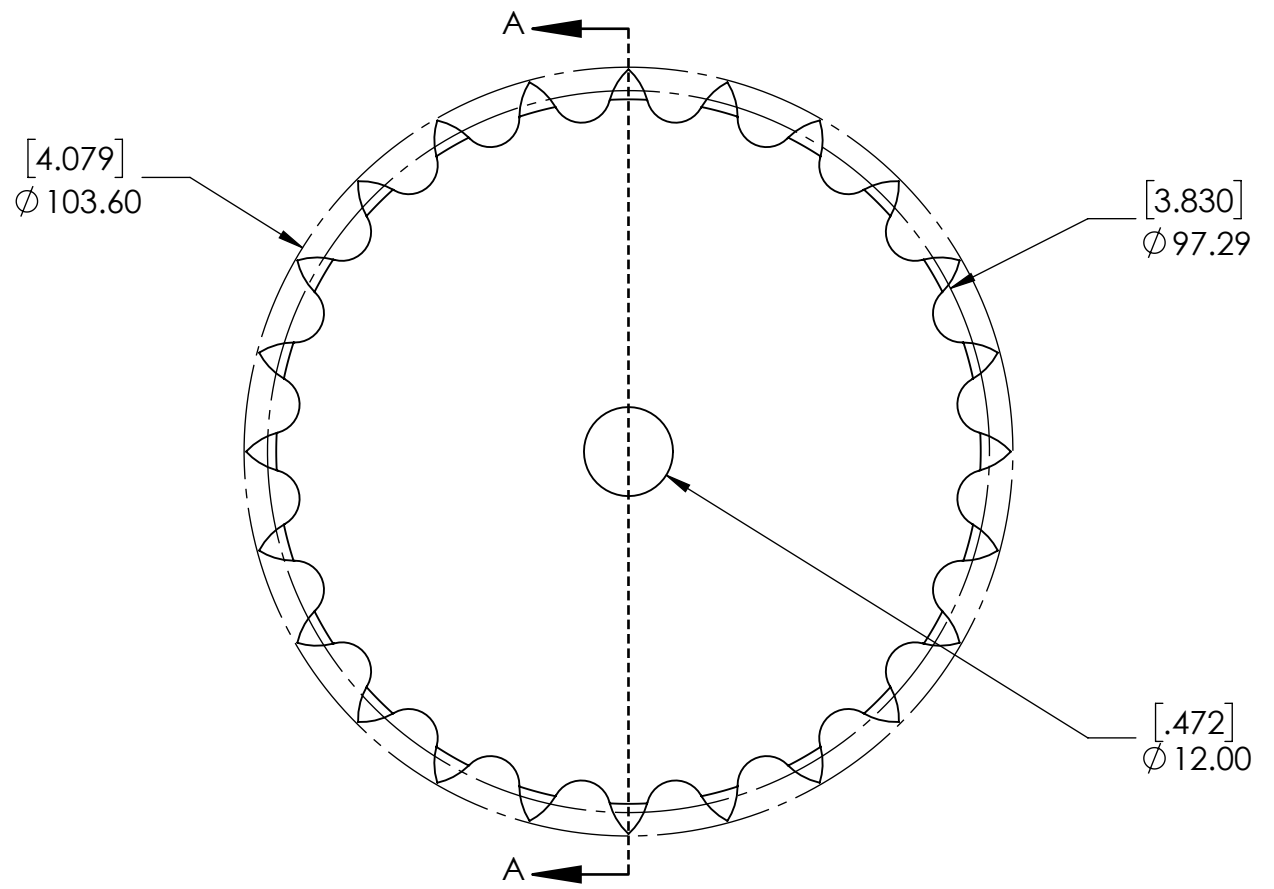

SECTION A-A

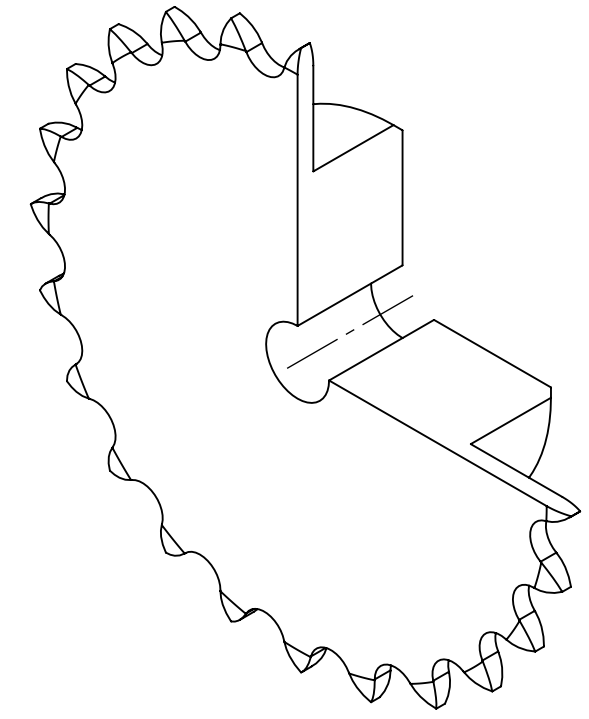

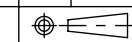
SPROCKETS SPECIFICATIONS		WEIGHT		1.15 LBS	
UNITS	mm (INCH)	MATERIAL	STEEL		
CHAIN SIZE	081B	COATING	BLACK OXIDE		
PITCH	12.70 mm	DRAWN	SEC	07/16/2025	
INNER WIDTH	3.30 mm	CHECKED	DH	08/14/2025	
ROLLER DIA.	7.75 mm	APPROVED			
TOOTH WIDTH	3.00 mm	DATE	BY	REVISION DESCRIPTION	
NUMBER OF TEETH	24	ITEM DESCRIPTION:		081B-24B	
HUB STYLE	B	DWG. NO.		SCALE	
BORE TYPE	PLAIN BORE	PROPRIETARY AND CONFIDENTIAL		1:1	
BUSHING NUMBER	N/A	<small>THE INFORMATION CONTAINED IN THIS DRAWING IS THE SOLE PROPERTY OF SOLVE IMG. ANY REPRODUCTION IN PART OR AS A WHOLE WITHOUT THE WRITTEN PERMISSION OF SOLVE IMG IS PROHIBITED.</small>		REV	
				-	

9 8 7 6 5 4 3 2 1