

9 8 7 6 5 4 3 2 1

G  
F  
E  
D  
C  
B  
A

G  
F  
E  
D  
C  
B  
A

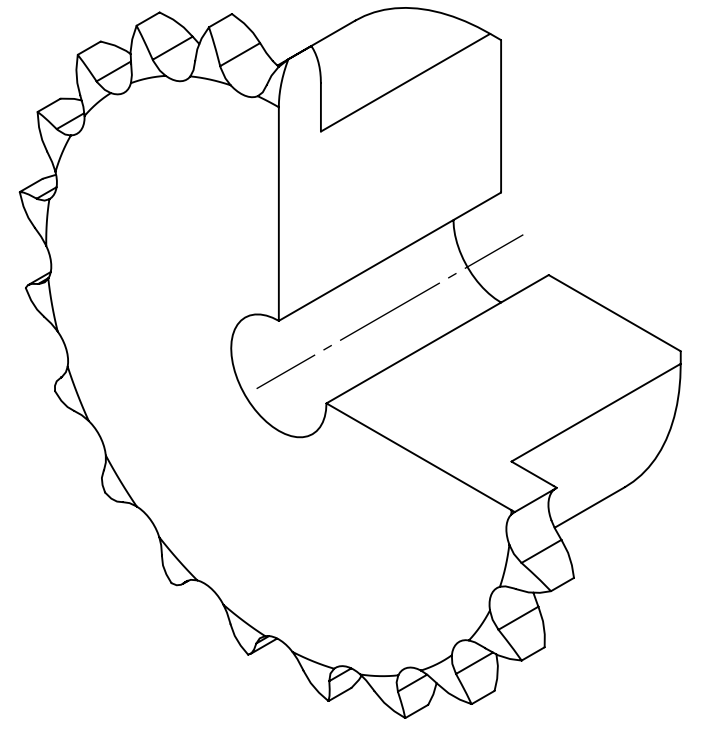
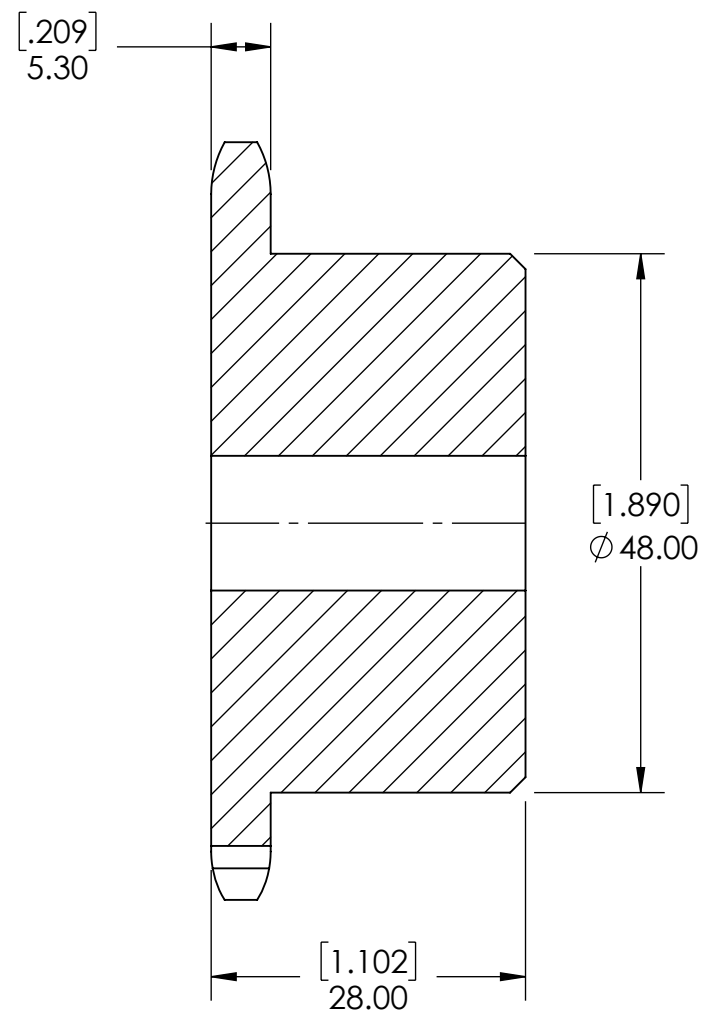
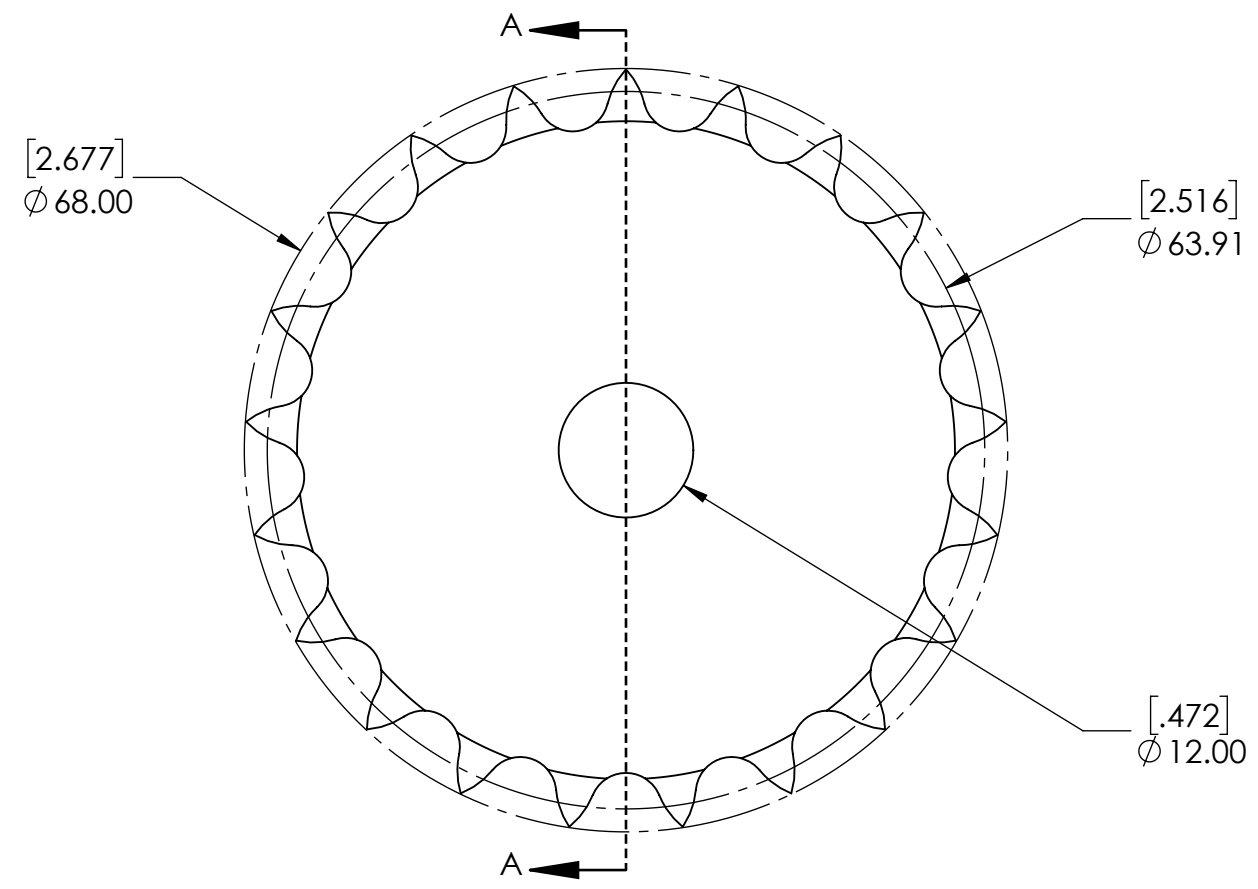

SECTION A-A

NOTES:  
1. HARDENED TEETH.

SPROCKETS SPECIFICATIONS		WEIGHT		DATE		BY		REVISION DESCRIPTION		REV
UNITS	mm (INCH)	0.92 LBS								
CHAIN SIZE	06B	MATERIAL	STEEL							
PITCH	9.525 mm	COATING	BLACK OXIDE	DRAWN		SEC		07/16/2025		
INNER WIDTH	5.72 mm	CHECKED	EG	07/16/2025						
ROLLER DIA.	6.35 mm	APPROVED								
TOOTH WIDTH	5.30 mm	THIRD ANGLE PROJECTION								
NUMBER OF TEETH	21	DWG. NO.		06B-21BH		ITEM DESCRIPTION:		06B-21BH		SCALE
HUB STYLE	B	PROPRIETARY AND CONFIDENTIAL		DATE		BY		REVISION DESCRIPTION		REV
BORE TYPE	PLAIN BORE	THE INFORMATION CONTAINED IN THIS DRAWING IS THE SOLE PROPERTY OF SOLVE IMG. ANY REPRODUCTION IN PART OR AS A WHOLE WITHOUT THE WRITTEN PERMISSION OF SOLVE IMG IS PROHIBITED.		07/16/2025						1:1
BUSHING NUMBER	N/A	PTI								-

9 8 7 6 5 4 3 2 1