

9 8 7 6 5 4 3 2 1

G F E D C B A

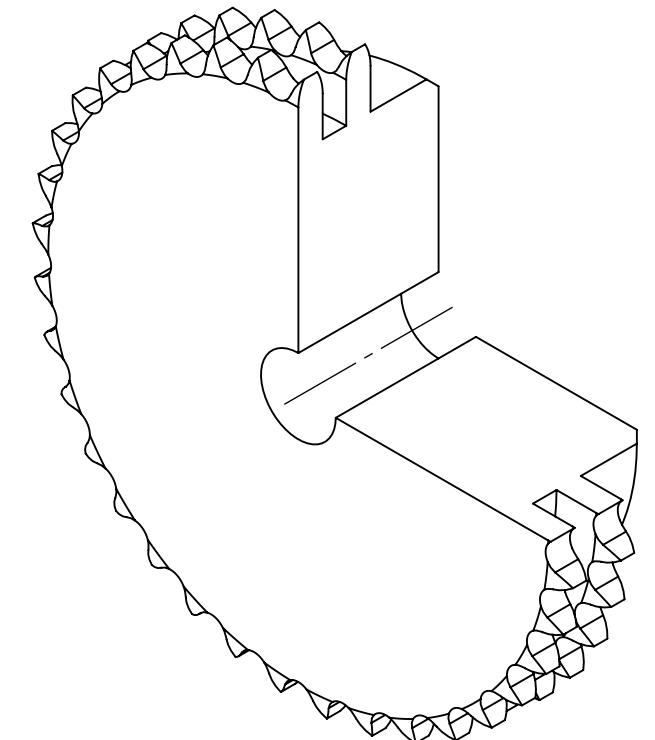
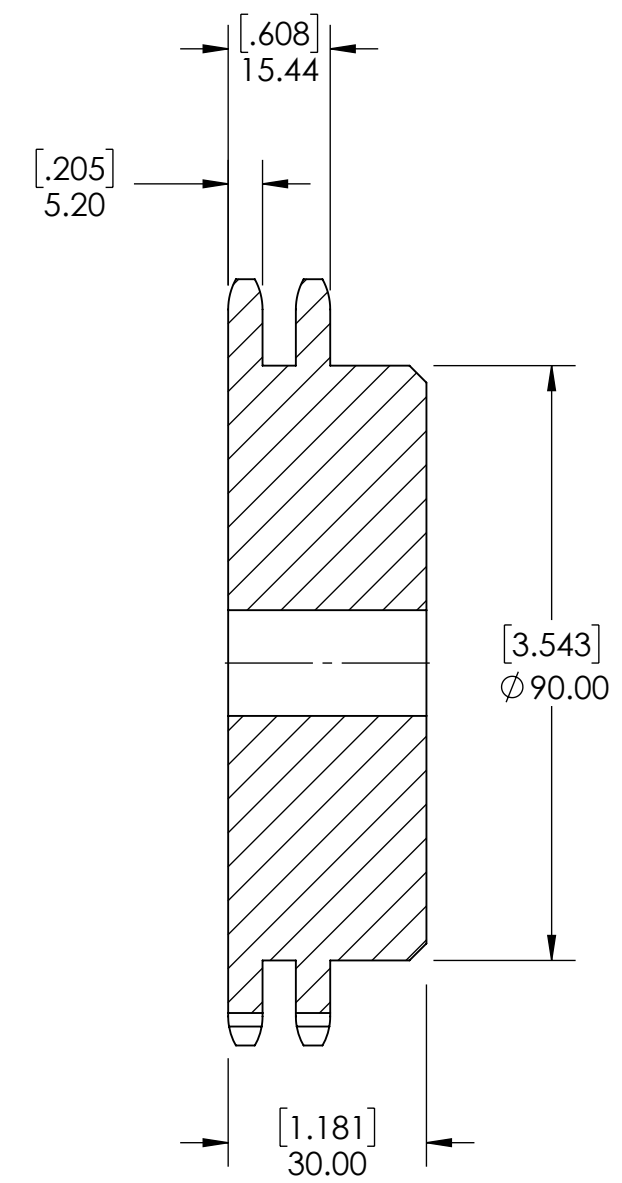
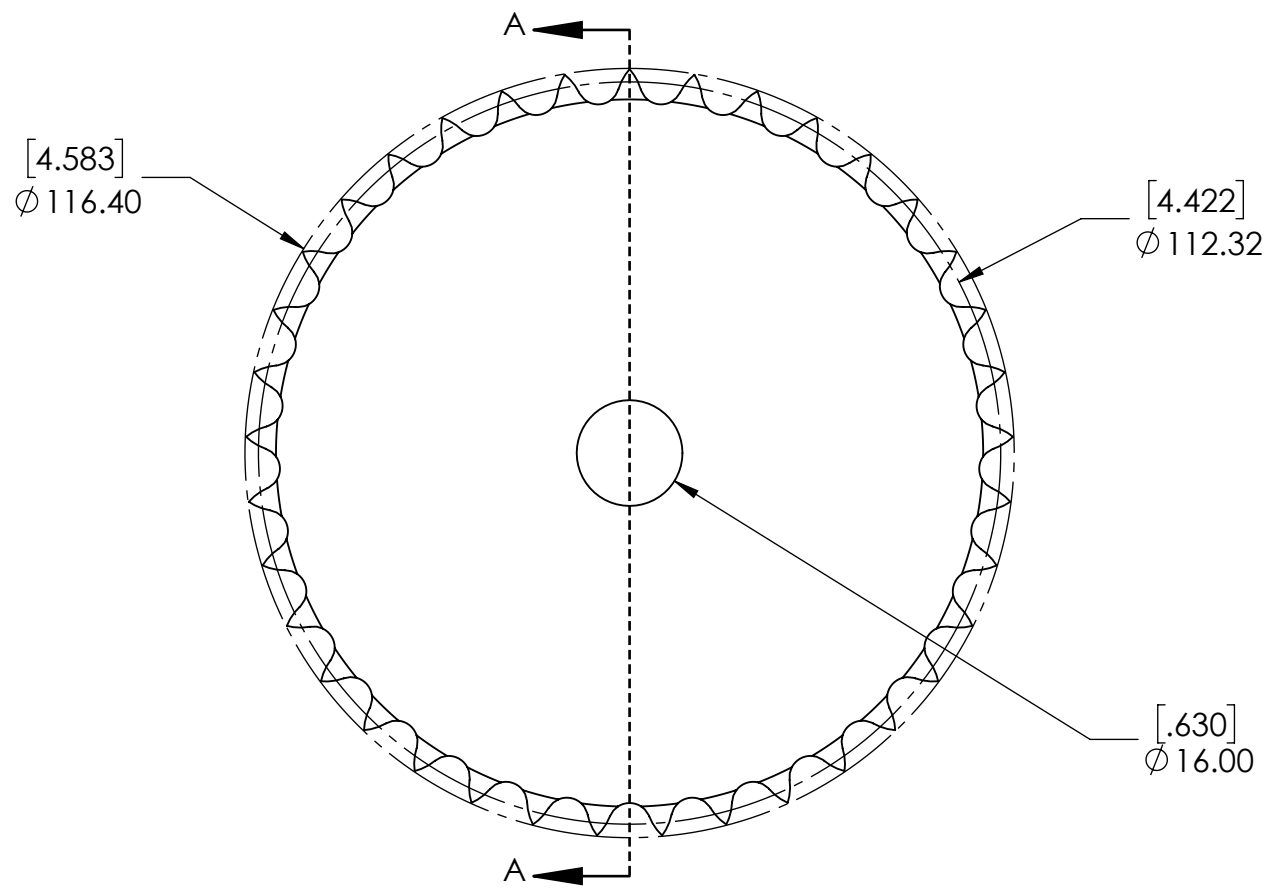

SECTION A-A

SPROCKETS SPECIFICATIONS		WEIGHT		DATE		BY		REVISION DESCRIPTION		REV
UNITS	mm [INCH]	3.72 LBS								
CHAIN SIZE	06B	STEEL								
PITCH	9.525 mm	BLACK OXIDE		DRAWN		SEC		07/30/2025		
INNER WIDTH	5.72 mm			CHECKED		EG		07/30/2025		
ROLLER DIA.	6.35 mm			APPROVED						
TOOTH WIDTH	5.20 mm							ITEM DESCRIPTION:		SCALE
NUMBER OF TEETH	37									
HUB STYLE	B			DWG. NO.		06B-2-37B				REV
BORE TYPE	PLAIN BORE			PROPRIETARY AND CONFIDENTIAL THE INFORMATION CONTAINED IN THIS DRAWING IS THE SOLE PROPERTY OF SOLVE IMG. ANY REPRODUCTION IN PART OR AS A WHOLE WITHOUT THE WRITTEN PERMISSION OF SOLVE IMG IS PROHIBITED.						-
BUSHING NUMBER	N/A									

9 8 7 6 5 4 3 2 1

A B C D E F G