

9 8 7 6 5 4 3 2 1

G F E D C B A

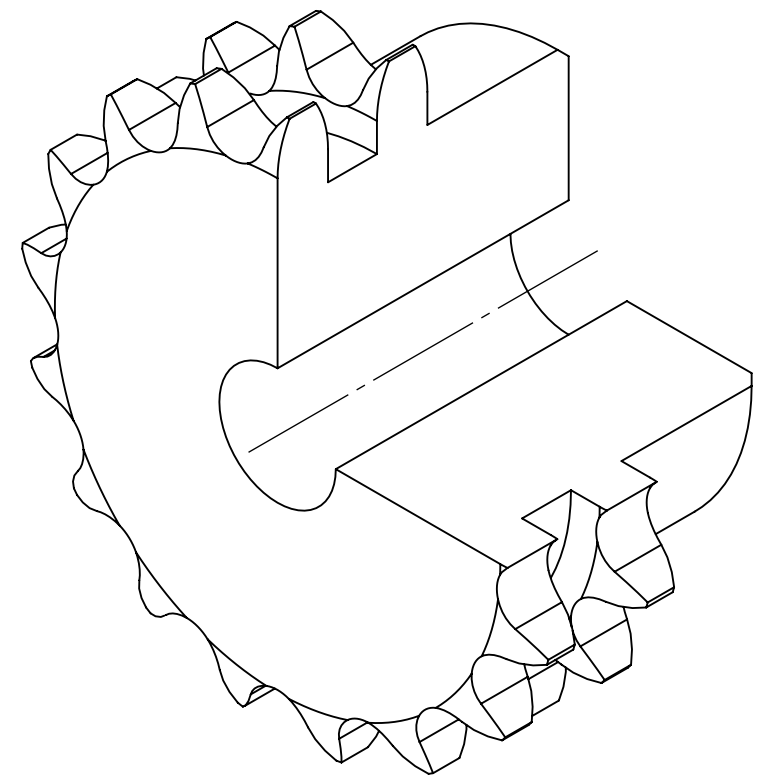
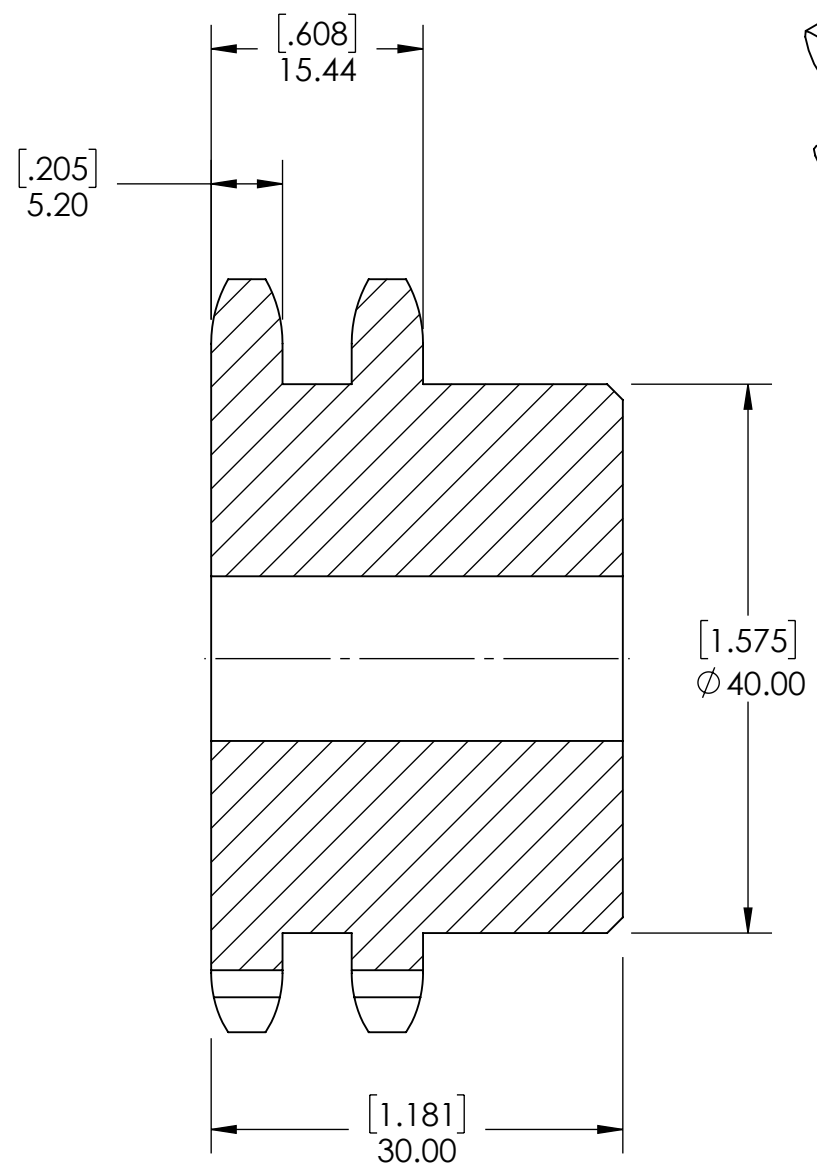
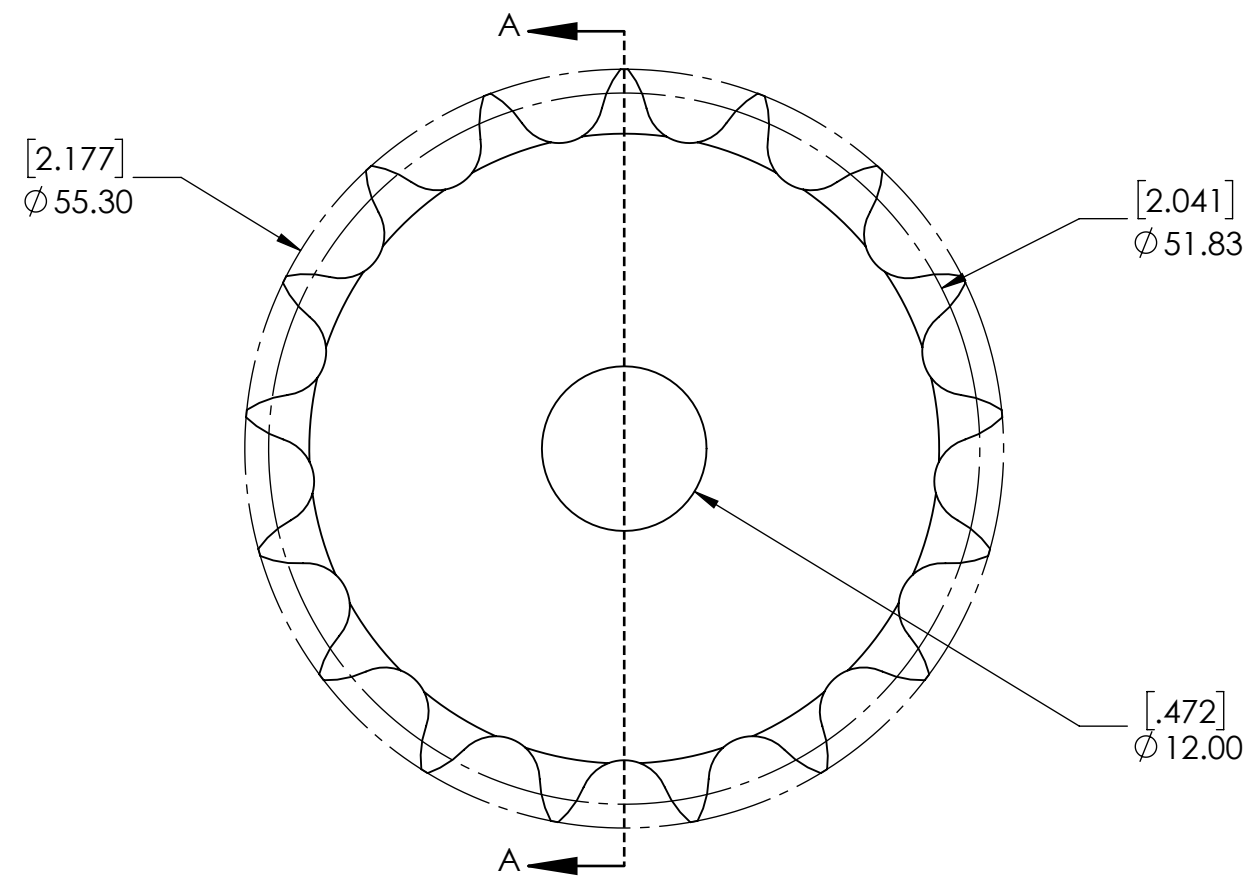

SECTION A-A

SPROCKETS SPECIFICATIONS		WEIGHT		0.70 LBS	
UNITS	mm (INCH)	MATERIAL	STEEL		
CHAIN SIZE	06B	COATING	BLACK OXIDE		
PITCH	9.525 mm	DRAWN	SEC	07/30/2025	
INNER WIDTH	5.72 mm	CHECKED	EG	07/30/2025	
ROLLER DIA.	6.35 mm	APPROVED			
TOOTH WIDTH	5.20 mm	DATE	BY	REVISION DESCRIPTION	
NUMBER OF TEETH	17	ITEM DESCRIPTION:			REV
HUB STYLE	B	06B-2-17B			SCALE
BORE TYPE	PLAIN BORE				1:1
BUSHING NUMBER	N/A				REV
		DWG. NO.	PROPRIETARY AND CONFIDENTIAL THE INFORMATION CONTAINED IN THIS DRAWING IS THE SOLE PROPERTY OF SOLVE IMG. ANY REPRODUCTION IN PART OR AS A WHOLE WITHOUT THE WRITTEN PERMISSION OF SOLVE IMG IS PROHIBITED.		

9 8 7 6 5 4 3 2 1

A