

9 8 7 6 5 4 3 2 1

G
F
E
D
C
B
A

G
F
E
D
C
B
A

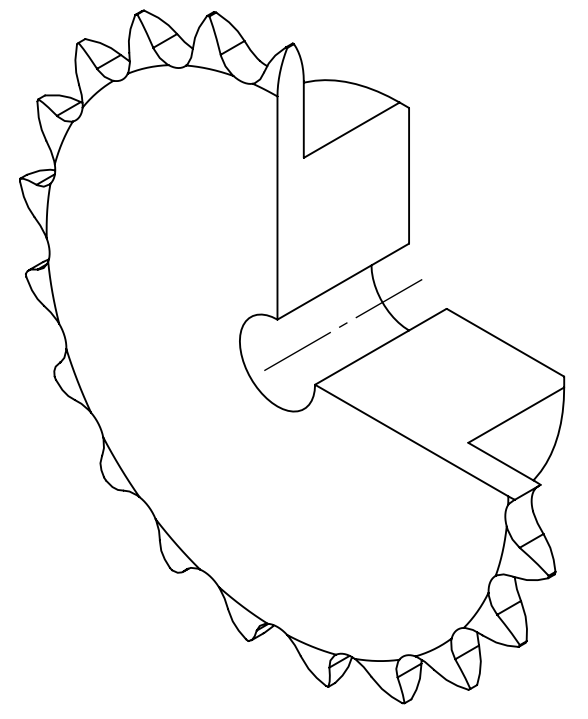
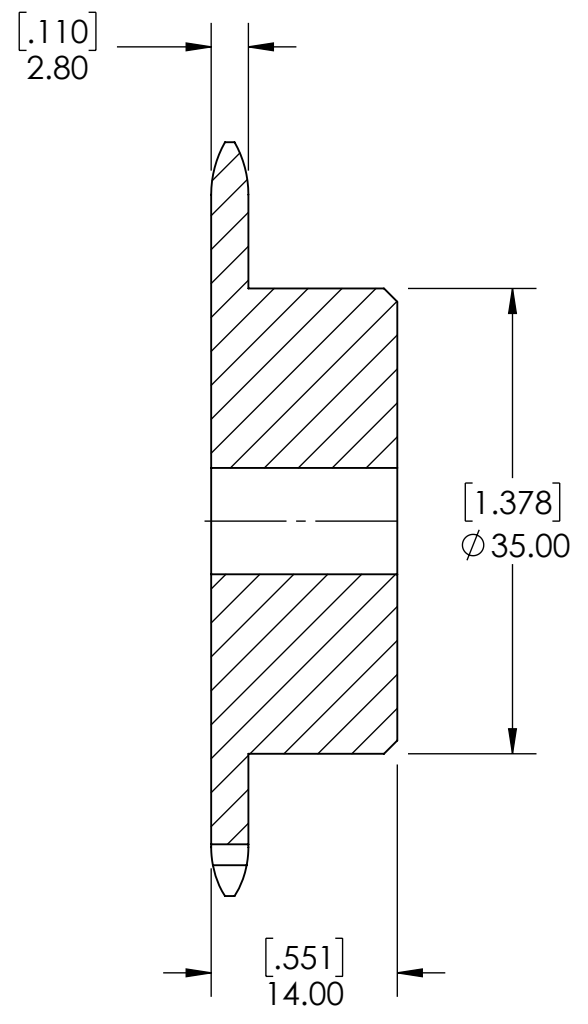
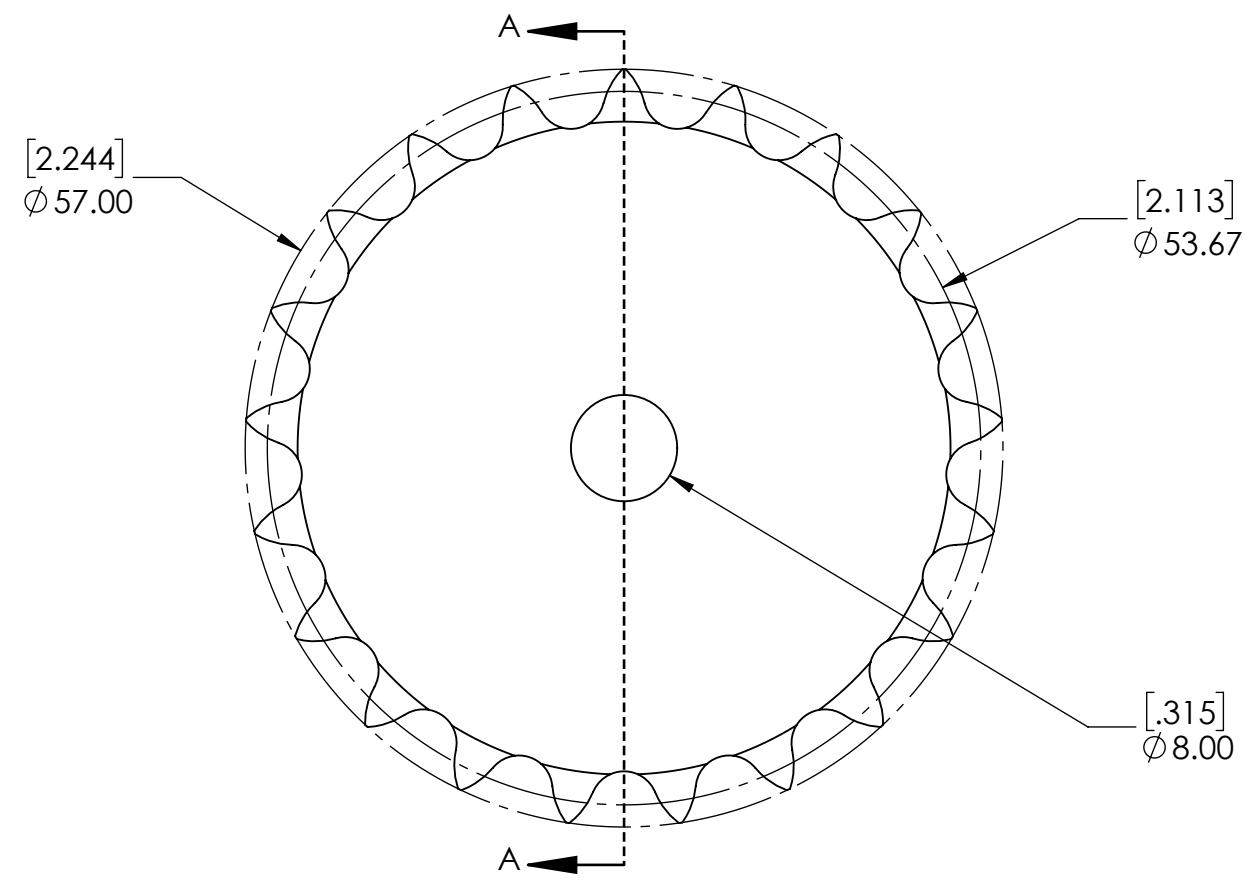

SECTION A-A

SPROCKETS SPECIFICATIONS		WEIGHT		DATE		BY		REVISION DESCRIPTION		REV
UNITS	mm (INCH)	0.27 LBS								
CHAIN SIZE	05B	STEEL								
PITCH	8.00 mm	BLACK OXIDE		07/16/2025						
INNER WIDTH	3.00 mm	DRAWN		SEC						
ROLLER DIA.	5.00 mm	CHECKED								
TOOTH WIDTH	2.80 mm	APPROVED								
NUMBER OF TEETH	21	THIRD ANGLE PROJECTION								
HUB STYLE	B	DWG. NO.								
BORE TYPE	PLAIN BORE	PTI		PROPRIETARY AND CONFIDENTIAL						
BUSHING NUMBER	N/A			THE INFORMATION CONTAINED IN THIS DRAWING IS THE SOLE PROPERTY OF SOLVE IMG. ANY REPRODUCTION IN PART OR AS A WHOLE WITHOUT THE WRITTEN PERMISSION OF SOLVE IMG IS PROHIBITED.						
				ITEM DESCRIPTION:		05B-21B		SCALE		1:1
								REV		-

9 8 7 6 5 4 3 2 1